

This is a consolidated bylaw, prepared by the City of Penticton for convenience only. The City does not warrant that the information contained in this consolidation is current. It is the responsibility of the person using this consolidation to ensure that it accurately reflects current bylaw provisions.

THE CORPORATION OF THE CITY OF PENTICTON

TRAFFIC BYLAW NO. 94-39

Consolidated for convenience only on

November 4, 1999

Amended on June 24, 2004 (2004-44)

Amended on June 19, 2006 (Bylaw 2006-35)

Amended on March 5, 2007 (Bylaw 2007-03)

Amended April 2, 2007 (Bylaw 2007-15)

Amended June 4, 2007 (Bylaw 2007-33)

Amended July 16, 2007 (Bylaw 2007-48)

Amended August 20, 2007 (Bylaw 2007-55)

Amended June 30, 2008 (Bylaw 2008-37)

Amended April 20, 2009 (Bylaw 2009-20)

Amended June 15, 2009 (Bylaw 2009-32)

Amended September 21, 2009 (Bylaw 2009-49)

Amended December 7, 2009 (Bylaw 2009-68)

Amended April 6, 2010 (Bylaw 2010-27)

Amended March 7, 2011 (Bylaw 2011-05)

Amended April 4, 2011 (Bylaw 2011-11)

Amended June 18, 2012 (Bylaw 2012-5025)

Amended by Bylaw 2012-5032-Sept. 17, 2012

INDEX

	<u>PAGE</u>
SECTION 1	Short Title..... 1
SECTION 2	Definitions 1
SECTION 3	Enforcement 8
	Part I Offences Other than Parking 8
	Part I-A Sidewalk Signs..... 11
	Part II Parking Regulations..... 12
	Parking Meters..... 16
	Parking Exceptions 18
SECTION 4	Penalties 19
SECTION 5	Removal of Vehicles and Chattels 20
SECTION 6	Extraordinary Traffic 23
SECTION 7	Noise..... 25
SECTION 8	Safety Equipment 25
SECTION 9	Uses Requiring Director's Permission 25
SECTION 10	Conditions of Director's Permission..... 26
SECTION 10A	Sidewalk Café Permits & Licence Agreements..... 28
SECTION 10B	Sidewalk Sales or Seating Area Permits and Licence Agreements.. 29
SECTION 11	Traffic Control Devices 30
SECTION 12	Vehicle Regulations 34
	A Prohibitions 35
	B Size & Weight Regulations 36
	1. Application 36
	2. Size and Load..... 36
	3. Weight 39
	4. Combination of Vehicles..... 41
	5. Permit 42
	6. Restricted Route Permits 43
	7. Weighing..... 45
	C Pilot Cars 46

SECTION 13	Parades.....	48
SECTION 14	Repeal Enactment	48
SECTION 15	Existing Traffic Orders Remain In Effect	48
SECTION 16	Severability Clause	49

SCHEDULE	"A" Application For Parking Space Removal	
	"B" Application For Parking Permit	
	"C" Complimentary Parking Permit	
	"D" Parking Exemption Permit	
	"E" Application for Extraordinary Traffic Agreement	
	"F" Application to Construct, Use, & Maintain Works Within a Roadway or Lane	
	"G" Application for Oversize, Overload, Overweight and Restricted Route Permit	
	"I" Main Street	
	"J" Resident Parking Only Placard	
	"K" Licence Agreement and Schedule "A" to Licence Agreement	
	"L" Sidewalk Café Specifications and Type 2, Sidewalk Café Design Guidelines	
	"M" Licence Agreement – Sidewalk Sales Area	
	"N" Sidewalk Sales Area Specifications and Sidewalk Seating Area Specifications	
	"O" Parking Stall Rental Licence	
	"P" Parking Codes for Bylaw Notice Infractions	
	"Q" Special Event Parking Only Placard	

**THE CORPORATION OF THE CITY OF PENTICTON
BYLAW NO. 94-39**

**A BYLAW OF THE CORPORATION OF THE CITY OF
PENTICTON TO REGULATE TRAFFIC AND THE USE
OF HIGHWAYS WITHIN THE BOUNDARIES OF THE
CITY OF PENTICTON**

WHEREAS pursuant to the relevant provisions of the Motor Vehicle Act and particularly Section 120 and relevant provisions of the Municipal Act and particularly Sections 579 to 584 inclusive, the Council is empowered to regulate traffic and the use of highways within the City of Penticton.

NOW THEREFORE, the Council of The Corporation of the City of Penticton in open meeting assembled ENACTS AS FOLLOWS:

SECTION 1 - SHORT TITLE

This Bylaw may be cited for all purposes as the "City of Penticton Traffic Bylaw No. 94-39 (1994)".

SECTION 2 - DEFINITIONS

In this Bylaw unless the context otherwise requires:

"Angle Parking" means the parking of a vehicle other than parallel to a curb or lateral lines of the roadway.

"Axle" means a structure in the same, or approximately the same, transverse plane supported by wheels and on or with which such wheels revolve. Any two axles of a vehicle, or combination of vehicles, the centres of which are less than 106 cm apart, shall be considered to be one axle for the purpose of this Bylaw.

"Arterial Highway" means highways classified as such pursuant to Section 31 of the Highways Act.

"Block Face" means the shortest portion of a Highway lying between two intersecting highways other than lanes.

"Boulevard" means that portion of a highway between the curb lines or the lateral lines of a roadway and the adjoining property or roadway, and includes curbs, sidewalks and ditches.

"Business" shall have the same meaning as defined under the City of Penticton Business Licence Bylaw No 2005-74 and as amended from time to time.

"Business Licence" shall have the same meaning as defined under the City of Penticton Business Licence Bylaw 2005-74 and as amended from time to time.

"Bylaw Enforcement Officer" shall mean a bylaw enforcement officer appointed by the City.

"Chief of Police" means the senior resident member of the Royal Canadian Mounted Police responsible for the policing of the Municipality.

"City" means the Corporation of the City of Penticton.

"Clerk" means the Municipal Clerk of the City of Penticton and his Deputy.

"Combination of Vehicles" means a combination of motor vehicles and trailer, or motor vehicle and trailers.

"Commercial Vehicle" means motor vehicles required by law to obtain a Municipal motor vehicle license plate.

"Commercially Zoned Property" shall mean property that is zoned as general commercial, tourist commercial or heavy commercial and commercial service, pursuant to the City of Penticton Zoning Bylaw No. 87-65 as amended from time to time.

"Council" means the Council of the City of Penticton.

"Crosswalk" means:

- (a) Any portion of the roadway at an intersection or elsewhere distinctly indicated for pedestrian crossing by signs or by lines or other markings on the surface, or
- (b) The portion of a highway at an intersection that is included within the connection of the lateral lines of the sidewalks on the opposite sides of the highway, or within the extension of the lateral lines of the sidewalk on one side of the highway, measured from the curbs, or in the absence of curbs, from the edges of the roadway.

"Cycle" means a device having any number of wheels that is propelled by human power and on which a person may ride.

"Dangerous Goods" means dangerous goods as defined in Section 1 of the Transport of Dangerous Goods Act SBC Chapter 17.

"Director" means the Director of Development and Engineering Services of the City and any other person or persons designated by the Director of Development and Engineering Services from time to time to act on his behalf.

"Drive Axle" means an axle that is or may be connected to the power source of a towing vehicle and transmits tractive power to the wheels.

"Farm Vehicle" means a commercial vehicle owned and operated by a farmer, rancher, or market gardener, the use of which is confined to purposes connected with his farm, ranch, or market garden, including use for pleasure and is not used in connection with any other business in which the owner may be engaged.

"Fees and Charges Bylaw" means the City for Penticton 2000 Fees and Charges Bylaw No. 2000-25 as amended from time to time.

"Gross Vehicle Weight" means the combined weight of the vehicle and its load.

"Gross Weight, Group of Axles" means the sum of the gross axle weights of all the axles comprising the group of axles.

"Gross Weight, Single Axle" means the gross weight carried by a single axle and transmitted to the road by the wheels of that axle.

"Gross Weight, All Axles" means the sum of the individual axle weights of all the axles of a vehicle or combination of vehicles.

"Group of Axles" means any two or more successive axles on a vehicle or combination of vehicles.

"Highway" includes every highway within the meaning of the Highway Act and every road, street, lane or right-of-way designed or intended for or used by the general public for the passage of vehicles and every place or passage way owned or operated by the City of Penticton for the purpose of providing off-street parking or for the use of pedestrian or cycle traffic.

"Horsepower" means the gross horsepower of the engine of the towing vehicle as customarily rated by the manufacturer.

"Impound" includes the seizure, removal and detention of any Vehicle, whether being

driven or not, and any other chattel which is unlawfully placed, left, kept or driven upon a street, or in any public park.

"Impounding Charges" includes all expenses of removal and detention or impounding and also towing, storage, and other charges, all as provided by Schedule 'B8' in Fees and Charges Bylaw 2000-25.

"Lane" means any highway not exceeding 8 m in width.

"Manager of Regulatory Services" means the person holding the office of Manager of Regulatory Services or his authorized representative.

"Metered Space" means a section of highway at which a parking meter has been installed.

"Minor Repair" means a non-structural repair or maintenance which does not require a permit under Building Bylaw No 94-45.

"Motor Vehicle" means a vehicle, not run upon rails, that is designed to be self propelled.

"Municipality" means the City of Penticton.

"Owner" in respect of any real property means the registered owner of an estate in fee simple, and in the event of there being registered a life estate includes the tenant for life. In the event that there is registered an agreement for sale and purchase, "owner" means the registered holder of the last registered agreement for sale and purchase. In the case of real property held in the manner mentioned in Sections 409 and 410 of the "Municipal Act", "owner" means the holder or occupier as therein set out; and for the purpose of this Bylaw shall include the registered owner of a motor vehicle.

"Parade" means any procession or body of pedestrians, except members of the armed forces, numbering more than thirty (30), standing, marching, or walking upon any highway, or any group of vehicles numbering ten (10) or more, excepting funeral processions, and excepting vehicles of the armed forces, standing or moving on any highway.

"Park" when prohibited, means the standing of a vehicle, whether occupied or not, except when standing temporarily for the purpose of and while actually engaged in loading or unloading.

"Peace Officer" means a constable or person having the powers of a constable and includes a By-law Enforcement Officer under the provisions of the Police Act.

"Pedestrian" means a person afoot, or an invalid or child in a wheelchair or carriage.

"Permit" means a document in writing issued pursuant to this Bylaw.

"Person" shall include any corporation, partnerships, firm or association and for the purpose of this Bylaw shall include the registered owner of a motor vehicle.

"Placard:" means a disabled person's parking placard issued by the Social Planning and Review Council of British Columbia.

"Purchasing Manager" shall mean the Purchasing Manager of the City.

"Residential Area" means any area zoned residential in the Zoning Bylaw of the City currently in force and shall include the highways abutting such zones and where the zone is different on the two sides of the highway the dividing line shall be taken to be the centre line of the highway.

"Residential Parking Only Area" means a designated Street Block whereby vehicles are prohibited from parking on one or both sides of the street during certain times and days, as posted, except that a vehicle displaying an appropriate Resident Parking Only Placard is permitted to park during the posted times and days.

"Resident Parking Only Placard" means parking Permit issued subject to this Bylaw and the City of Penticton policy for Resident Parking Only Areas.

"Roadway" means the portion of the highway that is improved, designed, or ordinarily used for vehicular traffic, but does not include the shoulder; and where a highway includes two or more separate roadways, the term "roadway" refers to any one roadway separately and not to all of the roadways collectively.

"S.A.M." means the portable crusher employed by the Provincial Government for the crushing of automobile bodies or similar private facilities.

"Semi Trailer" means a vehicle, other than a trailer, which is drawn by a motor vehicle and which is so constructed that some part of its weight and some part of the weight of its load rests upon, or is carried by the towing vehicle.

"Sidewalk" means the area between the curb-lines or lateral lines of a roadway and the adjacent property lines improved for use of pedestrians or any other improved area set aside for pedestrian use only.

"Sidewalk Café" means a portion of a City Sidewalk used for the service of food and beverages in connection with a restaurant or café use in an abutting building.

"Sidewalk Café Permit Holder" means a Person to whom a Permit has been issued under Section 10A.

“Sidewalk Sales Area” means a portion of a City Sidewalk located directly in front of a Commercially Zoned Property and used for the displaying of dry products for the purpose of retail sales.

“Sidewalk Sales Area License Agreement” means the Sidewalk Sales Area License Agreement referred to in Section 10B(3).

“Sidewalk Sales Area Permit” means a Person to whom a Sidewalk Sales Area Permit has been issued under Section 10B(1).

“Sidewalk Sign” means a temporary-removable sign placed upon a Sidewalk by a Business and that is not affixed or fastened to the Sidewalk in any way and has no external support structure.

“Sign Bylaw” means the City of Penticton Sign Bylaw No 92-22 as amended from time to time.

“Skateboard” means a narrow board about 2 feet long mounted on roller skates.

“Special Event Parking Only Area” means an area of the Highway designated by the Director whereby vehicles are prohibited from parking on one or both sides of the Highway during certain times and days, as posted except that a vehicle displaying an appropriate Special Event Parking Only Placard is permitted to park during the posted times and days.

“Special Event Parking Only Placard” means parking Permit issued subject to this Bylaw.

“Street Block” means a one-block section of a Street, Avenue, Drive or Road or other section of Highway (Street) for which a RPO has been approved or for which a RPO application has been made. The extent of a Street Block shall be defined as the smallest one-block section of Street that lies between two intersecting or cross Streets. A Street Block can include one side or both sides of the Street.

“Street Block Resident” means any person that resides in a Dwelling Unit at a property for which a RPO has been approved.

“Through Highway” means a highway or part of a highway at the entrances to which stop signs are erected under this Bylaw.

“Traffic” includes pedestrians, ridden or herded animals, vehicles, cycles and other conveyances, either singly or together, while using a highway for purposes of travel.

“Traffic Control Device” means a sign, signal, line, meter, marking, space, barrier, or device, placed or erected by authority of the Council or person duly authorized by the Council to exercise such authority.

"Traffic Control Signal" means a traffic control device, whether manually, electrically, or mechanically operated by which traffic is directed to stop and to proceed.

"Traffic Patrol" means an adult school crossing guard or a school pupil acting as a member of a school patrol where such guards or pupils are provided under the Public Schools Act or authorized by the Chief of Police.

"Trailer" includes a vehicle without motive power designed to be drawn by or used in conjunction with a motor vehicle and constructed so that no appreciable part of its weight rests upon or is carried by the motor vehicle, but does not include a house trailer or a trailer having a gross vehicle weight of less than 700 kg which is licensed pursuant to the Motor Vehicle Act.

"Truck Tractor" means a motor vehicle designed and used primarily for drawing other vehicles and not so constructed as to carry a load other than a part of the weight of the vehicle so drawn and of the load of such other vehicle.

"Type 1 Sidewalk Café" means a Sidewalk Café that comprises only a portion of the sidewalk adjacent to the business premises of which it is a part.

"Type 2 Sidewalk Café" means a Sidewalk Café that comprises the entire width of the sidewalk adjacent to the business premises of which it is a part, as well as a portion of a Roadway otherwise used for Motor Vehicle parking spaces.

"Vehicle" means a device in, upon, or by which a person or thing is or may be transported or drawn upon a highway, except a device designed to be moved by human power or used exclusively upon stationary rails or tracks.

"Wheel Base" means the distance, measured to the nearest foot between the centres of two (2) axles which are farthest apart.

"Width of Tire" means, with respect to rubber tires, the width of tire as customarily measured and rated by manufacturers of motor vehicles and tires and, with respect to metal tires or solid rubber tires, the transverse width of the outer circumference of the metal tire or solid rubber tire.

"Winter Tire" means a tire that is advertised or represented by its manufacturer or a person in the business of selling tires to be a tire intended principally for winter use and that provides or is designed to provide adequate traction in snow or mud and is in such condition respecting tread, wear and other particulars as the regulations under the Motor Vehicle Act may prescribe.

SECTION 3 - ENFORCEMENT

PART 1 - OFFENSES OTHER THAN PARKING

No person shall:

- | | | |
|------------------------|----|--|
| TRAFFIC CONTROL DEVICE | 1. | Except where otherwise directed by a Peace Officer or Bylaw Enforcement Officer or a person authorized by a Peace Officer or Bylaw Enforcement Officer to direct traffic, walk, or operate a vehicle or cycle contrary to the instructions of an applicable traffic control device erected pursuant to the provisions of this Bylaw. |
| ANIMALS | 2. | Unless otherwise permitted by an applicable traffic control device, drive a motor vehicle or ride or herd any animals, or ride a cycle, except for a wheelchair operated by a handicapped person, along any sidewalks, walkways or boulevards. |
| PLAY | 3. | Use skateboards, skates and other similar means of conveyance on a sidewalk or highway within that part of the City identified in Schedule I attached hereto and forming part of this Bylaw. |
| DEBRIS | 4. | Being the person who has removed a wrecked or damaged vehicle from the scene of an accident, leave any glass or other debris from the accident upon a roadway. |
| EXCAVATION | 5. | Leave any excavation or other obstruction upon a highway without sufficiently fencing, barricading and marking the same with warning lights. |
| PROCESSION | 6. | Drive or operate a vehicle between the persons or vehicles comprising a funeral procession or parade unless part of the funeral procession or parade. |
| OBSTRUCT | 7. | Stand or loiter in such a manner as to obstruct or impede or interfere with traffic on a highway. |
| TRACK VEHICLE | 8. | Operate track vehicles on sidewalks, boulevards, roadways or lanes except for the purpose of snow removal or grading. |

LANE	9.	Unless otherwise posted, drive a vehicle upon a lane in excess of 30 Km/h.
CONSTRUCTION	10.	Unless otherwise posted, drive a vehicle in excess of 30 Km/h in a zone where signs are posted indicating that the road is being repaired, widened or marked.
MERCHANDISE	11.	Place or permit to be placed any fuel, lumber, merchandise, chattel or ware of any nature on a highway.
SKIDDING	12.	Drag or skid anything along or over a highway so that the same damages the surface of the highway.
EARTH	13.	Being the owner or occupier of property abutting on a highway allow or permit any earth, rocks, stones, logs or stumps or other things to cave, fall, crumble, slide or accumulate from any such property onto a highway, or being there to remain thereon.
NOTICES	14.	Remove any notice of ticket affixed or placed on a vehicle by a City employee unless he is the owner or operator of such vehicle.
GARBAGE FACILITY	15.	Being the owner or occupier of property abutting a highway, allow any garbage containers or other facilities related to garbage collection to be upon any portion of the highway.
PARKS	16.	Drive a motor vehicle within the boundaries of any City Park except upon a roadway.
DITCHES	17.	Construct or maintain a ditch, the water from which causes damage to any highway.
LEAFLETS	18.	Distribute leaflets upon any highway by placing the same on the windshield or a motor vehicle parked upon the highway.
TRUCKS	19.	Unless otherwise posted with traffic control devices indicating a truck route, drive a truck with a gross vehicle weight in excess of 10,900 kg upon a roadway, except municipal or utility vehicles while engaged in work upon such highways, trucks carrying fruit from farm to packing house or trucks delivering goods and materials to properties on a street or streets directly serviced by such roadway.
INSECURE	20.	Operate a vehicle upon a roadway carrying any materials or

LOAD goods unless such materials or goods are secured so that the same cannot fall from the vehicle while the vehicle is proceeding along the roadway or permit any material or goods falling from a vehicle to remain upon a highway.

- | | | |
|-----------------------|-----|--|
| NO PASSING | 21. | Where a traffic control device so indicates, overtake and pass another vehicle in a designated school or park zone highway. |
| DANGEROUS
GOODS | 22. | Transport dangerous goods except on routes posted with traffic control devices indicating a dangerous goods route and on the most direct route between a dangerous goods route and his destination. |
| SOLICITING | 23. | No person shall solicit business upon or from a street without holding a valid and subsisting licence to do so issued pursuant to Bylaw #89-19 of The Corporation of the City of Penticton and amendments thereto, and without restricting the generality of the foregoing, no person being an owner or operator of a tow truck shall solicit towing business upon or from a street. |
| CARGO
COMPARTMENTS | 24. | Drive or operate a motor vehicle with any person riding in the cargo compartment of that motor vehicle, except for a parade authorized under Section 13 of the Bylaw. |
| LIQUOR | 25. | As a pedestrian, be in possession open liquor on a highway, including sidewalks or boulevards. |
| | 26. | Ride in a vehicle being driven or operated on or across a highway, unless seated on a seat that has been securely installed in the passenger compartment of the vehicle. |
| | 27. | A driver shall not drive a motor vehicle on a sidewalk, walkway or boulevard, except when entering or leaving a driveway or lane or when entering or leaving land adjacent to the highway. |
| | 28. | A person shall not ride or drive a bicycle or similar means of conveyance on any sidewalk, walkway or boulevard, except when entering or leaving a driveway or lane or when entering or leaving land adjacent to the sidewalk. (#99-36) |

PART I-A SIDEWALK SIGNS

No person shall place a Sidewalk Sign or advertising of any kind upon a Sidewalk, except in accordance with this Part:

- | | | |
|---|----|--|
| SIDEWALK SIGNS | 1. | A Business shall only place a Sidewalk Sign on a portion of Sidewalk directly fronting the address to which that Business is located. |
| LOCATION OF
SIDEWALK SIGN | 2. | Sidewalk Signs shall only be placed on Sidewalks such that the Sidewalk Sign or any part of the sign is set back 0.3 meters (1 foot) from the curb of the adjacent Roadway. |
| PLACEMENT AND
SPACING OF
SIDEWALK SIGNS | 3. | Where parking spaces are marked on the surface of the Roadway, a Sidewalk Sign shall only be placed on the Sidewalk such that the centre of the Sidewalk Sign is in line with a parking space marking. Where the Roadway does not include parking space markings, a Sidewalk Sign shall be placed on the Sidewalk such that it is not within 3 meters (10 feet) of any other Sidewalk Sign. |
| CROSSWALKS | 4. | A Sidewalk Sign shall not be placed upon a Sidewalk such that it is within 0.3 meters (1 foot) of a Crosswalk. |
| CLEAR WIDTH OF
SIDEWALK | 5. | A Sidewalk Sign shall not be placed on a Sidewalk such that the placement of the Sidewalk Sign or any part of the Sidewalk Sign will cause the clear and unobstructed width of the Sidewalk to be less than 1.5 meters (5 feet) as measured from the Sidewalk Sign or any part of the sign to any buildings, bench, planter, fixture, tree or any other object or obstruction located on or near the Sidewalk. |
| SIZE OF SIDEWALK
SIGNS | 6. | A Sidewalk Sign shall not exceed a maximum overall sign width or depth, including any sign base or stand, of 0.813 meters (32 inches) and shall not exceed a maximum overall height of 1.07 meters (42 inches), as measured from the surface of the Sidewalk to the highest part of the Sidewalk Sign or any attachment and shall be sturdy construction. |

REMOVAL OF SIDEWALK
SIGN

7. A Sidewalk Sign shall only be placed upon a Sidewalk during the times that the Business is open to the public and must be removed from the Sidewalk by the Business at all other times.

PART II - PARKING REGULATIONS:

- A. Except when necessary to avoid conflicts with traffic, to comply with the law, directed by a Peace Officer or Bylaw Enforcement Officer, traffic control device, traffic patrol, a Municipal or Provincial utility vehicle of a public utility corporation while engaged in their duties, a vehicle so mechanically disabled as to render it immobile or a duly licenced taxicab while loading or unloading customers; however the taxicab exception does not apply to school zones or bus zones during operational hours and crosswalks, no person shall stop, stand or park a vehicle:

- | | | |
|--------------|-----|---|
| SIDEWALK | 1. | On a sidewalk or boulevard. |
| DRIVEWAY | 2. | In front of a public or private driveway. |
| LANE | 3. | In any lane except an attended commercial vehicle actually loading or unloading and provided the vehicle is so placed to leave 3m of clear roadway. |
| INTERSECTION | 4. | Within an intersection except as permitted by a traffic control device. |
| HYDRANT | 5. | Within 5 m of a fire hydrant measured from a point on the curb or edge of the roadway which is closest to the fire hydrant. |
| CROSSWALK | 6. | On a crosswalk or within 6 m of the approach side of a crosswalk. |
| STOP SIGN | 7. | Within 6 m upon the approach to a stop sign or traffic control signal located at the side of a roadway. |
| EXIT | 8. | Within 6 m either side of the entrance to or exit from any hotel, theatre, public meeting place, fire hall or playground. |
| RAILWAY | 9. | Within 15 m of the nearest rail of a railway crossing. |
| SALES | 10. | Upon any highway for the principal purpose of:
a) displaying a vehicle for sale;
b) advertising, greasing, painting, wrecking, storing or |

		repairing any vehicle, except where repairs are necessitated by an emergency;
		c) displaying signs;
		d) selling flowers, fruit, vegetables, seafood, or other commodities or articles.
OBSTRUCTION	11.	Alongside or opposite a street excavation or obstruction when stopping, standing, or parking obstructs traffic.
DOUBLE PARKING	12.	On the roadway side of a vehicle stopped or parked at the edge or curb of a roadway.
BRIDGE	13.	Upon a bridge except as permitted by any applicable traffic control device.
SIGN	14.	In any place in contravention of a traffic control device that gives notice that stopping, standing, or parking is prohibited or restricted in such place.
	15.	In such a manner as to obstruct the visibility of any standard traffic control device erected by or with the authority of the Public Works Manager.
WRONG SIDE	16.	Upon a two-way roadway other than the right side of the roadway and with the right hand wheels parallel to that side.
DISTANCE	17.	On a roadway more than 30 cm from the curb of such roadway if a curb has been constructed.
ANGLE PARKING	18.	In a designated angle parking zone where the length of such vehicle and any trailer attached thereto exceeds 6 m.
RESERVE PARKING	19.	On any highway in a space adjacent to any Federal, Provincial or Municipal public building designed as being reserved for the use of Officials unless the operator is such Official.
HOURS	20.	On any highway for a continuous period exceeding twenty-four (24) hours without first obtaining the written permission of the Public Works Manager.
TRUCKS	21.	On any highway (adjacent to a residential area or on any highway across from a residential area where the area across from the residential area is zoned Parks & Recreation or

Institutional in the Zoning Bylaw of the City currently in force) a commercial vehicle having a gross vehicle weight in excess of 5,600 kg except when making deliveries and deliveries are only permitted between the hours of six o'clock in the forenoon and nine o'clock in the afternoon.

22. Within 3 m of the entrance or exit of a lane.
- OBSTRUCT 23. Upon a roadway in such a manner as to obstruct the free passage of traffic on the roadway.
24. Upon any portion of the highway where traffic control devices consisting of lines are painted upon the surface of the highway to designate parking areas, except within such designated space or area.
- CYCLE 25. On a portion of a highway that has been improved by the City for the purpose of cycle parking between such cycle parking and the roadway.
26. Upon a portion of a highway that has been improved and designated by traffic control devices for the travel of cycles.
- OVERTIME 27. a) On any highway where traffic control devices indicate the length of time allowed for parking, in contravention of the length of time indicated on the applicable traffic control device.
- b) Where a vehicle has been parked in a parking space on a roadway for any period of time, the owner or operator of such vehicle shall not during the next succeeding hour after having left such parking space park, or permit the parking of, such vehicle in the same or in any other parking space on the same side of the roadway in the same block.
- c) In order to determine the time which a vehicle has been parked in a location where parking is restricted to a specific time, a Peace Officer or Bylaw Enforcement Officer or other person charged with the enforcement of parking prohibitions and restrictions may place an erasable chalk mark on the tread face of the tire or parked or stopped vehicle without such Peace Officer or Bylaw Enforcement Officer or other person or the City incurring any liability for so doing.

PARKING LOTS	28.	On any public parking lot operated by the City of Penticton where traffic control devices indicate the length of time allowed for parking, in contravention of the length of time indicated on the applicable traffic control device.
LOADING ZONE	29.	In any area on public or private property that is designated by a traffic control device as a loading zone unless actively engaged in the authorized loading or unloading of a vehicle. (#99-39)
SCHOOLGROUND	30.	On a highway abutting a primary, elementary or junior secondary school ground or neighbourhood tot lot from dawn until dusk unless such school ground or tot lot is separated from the highway by a fence.
TRAILER	31.	<p>a) On any highway a trailer, a semi-trailer, mobile equipment or any vehicle which has been detached from the vehicle which is used to draw it.</p> <p>b) Where any type of motor vehicle has removable camping accommodation installed on it the operator or owner of the vehicle or any person in charge of the vehicle either permanently or temporarily shall not leave the camping accommodation or other removable portion of the motor vehicle used for this purpose on any portion of a highway after the same has been removed from the motor vehicle.</p>
PARKING FOR DISABLED	32.	In any parking space on public or private property that is designated by order of the Public Works Manager under Section 11 of this bylaw as a disabled person's parking space except where the motor vehicle bears, hanging from the inside rear view mirror, a placard in the form and with the consent set out in the order of the Public Works Manger. (#99-39)
EMERGENCY VEHICLES	33.	In any area on public or private property that is designated by a traffic control device to be reserved for the use of emergency vehicles. (#99-39)
RESIDENT PARKING ONLY AREA	34.	On a portion of Highway designated by Traffic Control Devices as a Resident Parking Only Area except Vehicles displaying a valid Resident Parking Only Placard.
SPECIAL PARKING ONLY AREA	35.	On a portion of Highway designated as a Special Event Parking Only Area, except vehicles displaying a valid Special

Event Parking Only Placard.

B. Parking Meters

- AUTHORIZED METER SPACES
1. All parking meters and metered spaces in effect immediately prior to the coming into force of this bylaw shall continue in effect until removed pursuant to this bylaw.
 2. The Public Works Manager may:
 - a) authorize such other or additional metered spaces as is deemed necessary on any street or other City owned property for use as a metered space,
 - b) cause the spaces so authorized to be marked for this purpose, and
 - c) cause a parking meter to be installed adjacent to each such metered space.
- DEPOSITING COINS
3. The operator of any vehicles, except one which is not allowed to use a metered space pursuant to this bylaw, shall immediately after parking his vehicle in such a metered space deposit or cause to be deposited in the parking meter adjacent to such space in accordance with the instructions shown on the parking meter, a Canadian coin or coins of the type and the denomination indicated in the instructions on the meter, and shall turn the handle of the parking meter in accordance with such instructions.
 4. After placing the coin or coins in the meter and having turned the handle the operator of the vehicle may, subject to any restrictions indicated by applicable traffic signs or markings park his vehicle in the metered space appurtenant to the parking meter for the period indicated on the parking meter.
- METER VIOLATION
5. Subject to subsection 6, no owner or operator of a vehicle shall permit such vehicle to remain in a metered space while the signal "Violation" or "Time Expired" is in view on such parking meter.
- WHEN COINS NOT REQUIRED
6. Subject to subsection 10 and notwithstanding the other provisions of this section, a metered space located on a street may be used without charge:
 - a) on holidays, on Sundays and on any other day of the week between the hours of six o'clock in the evening and nine o'clock in the following forenoon;

SERVICE VEHICLES	b)	by vehicles of the City or of the federal and provincial government departments if properly designated by the appropriate City or government crests, or by emergency vehicles and by such other vehicles as the Public Works Manager may designate, in every case only while the operators of all such vehicles are actually engaged in the course of their employment;
DELIVERING	7.	The drivers of vehicles delivering goods, wares and merchandise, may use a metered space without charge on any day up to ten-thirty (10:30 a.m.) in the forenoon.
TAXICABS	8.	The drivers of taxi cabs may use a metered space without charge, but only when taking on or discharging passengers, and, in any event, for a period not exceeding two (2) minutes.
HOODING	9.	The Public Works Manager, upon receipt of an application in the form of Schedule "A", may cause any metered space to be removed from use as such by causing the parking meter to be hooded up or removed and may cause the space formerly set aside as a metered space to be designated for some other use. Similarly, the Public Works Manger may cause any non-metered controlled parking space to be removed from use as such and a sign be posted at such meter(s) stating "No Parking Except By Permit".
FEE CHARGED	10.	Where a metered space is hooded for the benefit of a person other than for a purpose required by the City the person for whose benefit it is hooded shall pay a fee in accordance with the current City of Penticton Fees and Charges Bylaw. This fee will also apply to any non-metered, controlled parking space required for some other use.
PERMIT	11.	Only those vehicles designated by permit will be permitted to park in a parking space subject to a permit issued by authority of paragraphs 9 and 10 of this section.
TAMPER WITH METER	12.	No person shall: <ul style="list-style-type: none"> a) deposit a slug, device or metallic substitute for coins in any meter or b) deface, injure, tamper with, open, wilfully break, destroy or impair the usefulness of any parking meter.
PARKING IN METERS SPACE	13.	Except as otherwise provided in this section where parking spaces have been marked on any roadway unless the Act, another provision of this bylaw or a traffic control device

otherwise permits, no owner or operator of any vehicle shall stop or park or permit to be stopped or parked such vehicle other than between the lines or markings indicating the limits of a single parking space.

14. Unless the Act or another provision of this bylaw otherwise permits when parking a motor vehicle in a metered space no owner or operator of the vehicle shall so park or permit it to be so parked so that it is other than wholly within the metered space and not to cross any painted line marking out such space.
15. Where a vehicle exceeds the length of a single parking space or metered space the operator may park such vehicle so that it occupies two but not more than two parking or metered spaces, as the case may be.
16. When pursuant to subsection 13 a person parks a motor vehicle so as to occupy two metered spaces the required coin or coins shall be inserted in each of the parking meters appurtenant to the metered spaces.

PARKING IN
TWO METERED
SPACES

C. Exceptions

MISCELLANEOUS PARKING PERMITS Notwithstanding the provisions of Section 3 Part II Subsections A(28) and B(3), a person holding a permit issued pursuant to the provisions hereof or a placard issued in compliance with Section A(32), A(34), or A(35) shall not be subject to the penalties provided for the breach of those Subsections so long as that permit or placard remains valid and subsisting.

1. (a) The Public Works Manager, upon receipt of an application in the form of Schedule "B", may issue a permit to any person prepaying to the City an hourly or a monthly parking fee either by use of a mechanical device or otherwise.
- (b) The parking fee shall be the amount designated by the Council as the applicable parking fee for the particular parking area for which the permit is issued.
- (c) The printed permit shall be displayed by the Permittee on the dashboard on the inside of the windshield of his vehicle and should the permit not be so displayed or should the permit have expired the vehicle shall be deemed to be parked without a permit.
- (d) The permit shall specify the parking area for which the

permit is issued and shall be valid only for the parking area so designated and only for the period of time as provided for in the permit.

- (e) Where a permit is issued for the rental of a parking stall and that rental is for a period of one month or more, the person to whom the permit is issued shall complete and sign a parking stall rental licence in the form of Schedule O, and the Manager of Regulatory Services is authorized to sign such parking stall rental licence on behalf of the City.
2. The Mayor or the Public Works Manager of the City of Penticton may issue complimentary parking permits in the form of Schedule "C".
 3. The Public Works Manager may issue parking exemption permits in the form of Schedule "D".
 4. The Administrative Manager as defined in the City of Penticton Policy for Resident Parking Only Areas may issue Resident Parking Only Placards in the form of Schedule "J".
 5. The Director may issue Special Event Parking Only Placards in the form of Schedule "Q".

SECTION 4 - PENALTIES

VIOLATION	Any person who operates a motor vehicle, or who, being the owner or operator of a motor vehicle, permits it to stand or be parked in contravention of a traffic control device or signal is liable on summary conviction to a fine of not more than Two Thousand Dollars (\$2,000.00).
PENALTY	Except as otherwise provided in this Bylaw, every person who violates any of the provisions of this Bylaw or who suffers or permits any act or thing to be done in contravention of this Bylaw, or who refuses, or omits or neglects to fulfil, observe, carry out or perform any duty or obligation imposed by this Bylaw is liable on summary conviction to a fine not exceeding Two Thousand Dollars (\$2,000.00).
DEFAULT	Wherein this Bylaw any matter or thing is required to be done by any person in default of it being done by such person, such matter or thing shall be done at the expense of the person in default and the expense thereof may be recovered, with interest at the rate of ten percent (10%) per annum, with costs in like manner as municipal

taxes.

INSPECTION

Any Peace Officer or Bylaw Enforcement Officer, the Public Works Manager or employee of the City Public Works Department may enter, at all reasonable times, upon any property subject to the regulations of this Bylaw in order to ascertain whether such regulations or directions are being obeyed.

SECTION 5 - REMOVAL OF VEHICLES AND CHATTELS

IMPOUNDING

1. (a) Any Bylaw Enforcement Officer, Peace Officer or employee of the City designated by the Director to carry out the provisions of this Bylaw may Impound or cause to be impounded any Vehicle, whether being driven or not, which is unlawfully placed, left, kept or driven upon a street or in any public park.
- (b) Every Vehicle which has been impounded shall be kept at such premises as may be designated by the Director and shall there be kept at the owner's risk.
- (c) For the purposes of this section, a Vehicle is deemed to be unlawfully left on a street if the Vehicle has:
 - (i) the sound of an automobile security system made either continuously or intermittently, for a period exceeding one minute, or the sound of an automobile security system, not including its activation status signal, more than three times in a 24-hour period; or
 - (ii) a horn that is audibly sounding for a period of more than ten minutes.

IMPOUND CHARGES

2. This Bylaw fixes as the Impounding Charges, the rates set out in Schedule B8 in Fees & Charges Bylaw 2000-25, and authorizes the payment of such rates to any person with whom the City contracts for the removal, towing, or storage of an impounded Vehicle or the removal of a chattel or other personal property under this Bylaw."

RECOVERY

3. (a) An impounded Vehicle may be recovered by its owner if, prior to the sale provided for in paragraph 5, the owner can show satisfactory proof of ownership and pays the Impounding Charges, except that the Director may, if the Impounding Charges are paid, give possession of the Vehicle to any other person who provides satisfactory evidence of entitlement to the Vehicle.

- (b) Notwithstanding anything contained in this Bylaw, the owner of an impounded Vehicle who feels that payment of the required Impounding Charges will cause him or her undue hardship may write out a claim of hardship directed to the Director and if the Director, after considering and weighing the circumstances of the case, accepts the owner's claim of hardship the Director may recommend to Council that all or any part of the Impounding Charges be waived. The decision of Council shall be final and binding.

NOTICE

- 4. (a) Upon any Vehicle being impounded, the Director, where the impounding has been effected by a Peace Officer or a Bylaw Enforcement Officer shall cause enquiry to be made as to who is the owner of such Vehicle, or is entitled to claim possession thereof.
- (b) In respect of Vehicles registered in British Columbia, the Director shall within seven days of the impounding of such Vehicle forward a notice in writing to the registered owner as shown by the records maintained by the Superintendent of Motor Vehicles.
- (c) In respect of Vehicles registered outside British Columbia, the Director shall forward such notice aforesaid within twenty-one days of the impounding of such Vehicle to such person as the Director shall, after enquiry, deem to be the owner of the said Vehicle or entitled to claim possession of the same.
- (d) The said notices shall contain a description of the said Vehicle, a statement of the scale of Impounding Charges and the address where the said Vehicle is held, and shall also state a date after which the said Vehicle will be sold, which date shall be at least thirty days from the date that such Vehicle came into the possession of the Director.

DISPOSAL

- 5. (1) Any Vehicle which remains unclaimed after the date prescribed by the Director pursuant to clause (d) of paragraph 4 hereof shall be delivered to the Purchasing Manager for disposal in the manner hereinafter provided.
- (2) (a) The Purchasing Manager, where of the opinion that the value of an impounded Vehicle is such that it should be scrapped or disposed of for parts, shall sell at the best advantage, or dispose of at the least cost, by public auction, solicited offers, negotiated sale, or other method which will best serve the interests of the City. For Vehicles in this condition the Purchasing

Manager may arrange to have a person or firm remove such Vehicles on a continuing basis, as they become available.

- (c) The Purchasing Manager, where of the opinion that the value of an impounded Vehicle is such that is suitable, with or without repairs, for licensing and return to service, shall sell such Vehicle by public auction, solicited offers, or negotiated sale. If such sales methods fail to bring a satisfactory price, the Purchasing Manager may dispose of such Vehicles in accordance with clause (a) of this subparagraph (2).

SALE

- 6. Upon the sale of any Vehicle pursuant to the provisions hereof, the Purchasing Manager shall pay the net proceeds of sale to the City Treasurer who shall, after deducting impounding and other charges, hold any balance for any lawful claimant thereto.

RECORDS

- 7. The Director shall cause to be kept a record of every Vehicle impounded pursuant to the provisions of this Bylaw. Such record shall be adequate and sufficient to identify the Vehicle in question, and shall also give details of the time when and the place where the said Vehicle was impounded, and of the full amount of the Impounding Charges up to the date of sale or restoration thereof.
- 8. Every Person who attempts to prevent the impounding of any Vehicle or who in any manner interferes with the impounding of any such Vehicle shall be deemed to be guilty of an infraction of this Bylaw and shall be liable to the penalties provided herein.

PEACE
OFFICER

- 9. Every Vehicle which comes into the hands of a Peace Officer for any reason other than as a result of impounding shall be held and dealt with in accordance with the provisions of this Bylaw, but no Impounding Charge shall be imposed in respect thereof until seven days after a date to be fixed by the Peace Officer, after which all provisions of this Bylaw shall apply thereto.

CHATTELS

- 10.(1) The Director may Impound or cause to be impounded, any chattel or other personal property, not including a Vehicle which is unlawfully placed, left or kept upon a street.
- (2) the owner of a chattel or other personal property impounded pursuant to subparagraph (1) shall be responsible for the payment of all Impounding Charges.
- (3) The owner of a chattel or other personal property who has paid all Impounding Charges and has proved title/ownership to the chattel or other personal property to the satisfaction of

the Director may recover possession of the chattel or other personal property provided that such possession is taken within one month from the time of the impounding.

- (4) Any chattel or other personal property which remains unclaimed after the date prescribed by subparagraph (3) shall be delivered to the Purchasing Manager to be disposed of in the same manner as provided for in paragraphs 5 and 6 herein."

SECTION 6 - EXTRAORDINARY TRAFFIC

- 1. In this Section:

DEFINITION

"Extraordinary Traffic" includes any carriage of goods or persons over a highway, at either one or more times, and whether in vehicles drawn by animal power or propelled by some other means, that taken in conjunction with the nature or existing condition of the highway is so extraordinary or improper in the quality or quantity of the goods or the number of persons carried, or in the mode or time of use of the highway, or in the speed at which the vehicles are driven or operated, as, in the opinion of the Public Works Manager, substantially to alter or increase the burden imposed on the highway through its proper use by ordinary traffic, and to cause damage and expense in respect of the highway beyond what is reasonable or ordinary.

PROHIBIT USE

- 2. Where in the opinion of the Public Works Manager, any highway is liable to damage through extraordinary traffic thereon, he may regulate, limit or prohibit the use of the highway by any person operating or in charge of the extraordinary traffic, or owning the goods carried thereby or the vehicles used therein.

MAXIMUM FINE

- 3. Every person driving on or using the highway in contravention of a regulation, limitation, or prohibition made under Sub-section 2 is guilty of an offence against this Bylaw, and is liable on summary conviction, to a fine of not less than Fifty Dollars (\$50.00) and not more than Three Hundred Dollars (\$300.00).

COMPENSATION

- 4. Any person to whom this Section might otherwise apply may, with the approval of the Public Works Manager, enter into an

agreement in the form of Schedule "E" for the payment to the Municipality of compensation in respect of the damage or expense which may, in the opinion of the Public Works Manager, be caused by the extraordinary traffic, and thereupon that person shall not in respect of that traffic be subject to any prohibition or penalty prescribed in this Section.

CLOSE HIGHWAY 5. The Public Works Manager may close to traffic or use any highway at such time and for such period of time and in respect of such classes of traffic or use as in his opinion may be necessary for the construction or protection of any highway or other public works or for the protection of persons using the highway or to enable permitted traffic to be handled safely and expeditiously.

SKATEBOARDS 6. A person may use a skateboard or skates
SKATES i) on a sidewalk except within that area of the City identified in Schedule I or unless otherwise directed by a sign;
ii) for the purpose of crossing a highway, on a crosswalk, except within that area of the City identified in Schedule 1 unless otherwise directed by a sign.

SKATEBOARDS 7. Notwithstanding the authority given a person using a skate-
SKATES board or skates by Subsection 6, no person shall use a skateboard or skates on a sidewalk, a crosswalk or on a highway without due care and attention or without reasonable consideration for other persons using the sidewalk, crosswalk or highway. Schedule 1 - Map

SECTION 7 - NOISE

1. No person shall make or cause any noise or sound on a highway or elsewhere within the corporate limits of the City which disturbs or tends to disturb the quiet, peace, rest, enjoyment, comfort or convenience of the neighbourhood or of persons in the vicinity.
2. No person shall drive or operate a motor-vehicle within the corporate limits of the City so as to cause, or in a manner causing loud noise from the tires, or engine or exhaust of such motor-vehicle.
3. City sanctioned activities and events are exempted from the provisions of subsections (1) and (2) above.

SECTION 8 - SAFETY EQUIPMENT

1. The Public Works Manager may, by public notice or by the placing of signs, prohibit vehicles which are not equipped with chains, or winter tires, or sanding devices, or any combination of these which the Public Works Manager may consider necessary in view of prevailing road conditions, from being driven or operated on a highway.
2. This Section does not apply to arterial highways.

SECTION 9 - USES REQUIRING THE DIRECTOR' S PERMISSION

This Section does not apply to arterial highways.

Except as authorized by a permit issued by the Director pursuant to Section 10 of this Bylaw, or the Manager of Regulatory Services pursuant to Section 10A or Section 10B of this Bylaw" no person shall:

- | | |
|-------------------------------|--|
| EXCAVATIONS
CUTTING TIMBER | 1. Dig up, break up or remove any part of a highway, or cut down or remove trees or timber growing on a highway, or excavate in or under a highway. |
| DAMAGE TO
BOULEVARDS | 2. Cause damage to, cut down or remove trees, grass, shrubs, plants, bushes and hedges, fences, signs, or other things erected by the Municipality on a highway. |
| STOPPING | 3. Change the level of a highway whatsoever, or stop the flow of |

WATER		water through any drain, sewer or culvert on or through a highway.
STRUCTURES	4.	Place, construct or maintain a loading platform, skids, rails, mechanical devices, buildings, signs or any other structure or thing on a highway excluding ladders or other equipment used to maintain or complete minor repairs to the front of a premise adjacent to a sidewalk provided: <ul style="list-style-type: none"> • The work area does not occupy more than one half the width of the sidewalk abutting the premise or leave less than 1.5 meters (4.9 ft.) of clear unobstructed sidewalk for pedestrian use; • The work area is identified in a manner, acceptable to the Bylaw Enforcement Officer, so as to alert pedestrians of the work area and direct pedestrians around the work area; and • All work materials are contained within the work area.
EFFLUENT FROM DRAIN	5.	Construct or maintain a ditch, sewer or drain, the effluent from which causes damage, fouling nuisance or injury to any portion of a highway.
DEFACING	6.	Mark or imprint or deface in any manner whatsoever a highway or structure thereon.
SIGNS	7.	Erect or maintain any sign, advertisement or guide-post on or over any highway or alter, repaint, tear down or remove any sign, advertisement or guide-post erected or maintained on any highway.
BOULEVARD	8.	Ride, drive, lead, move or propel any vehicle or animal in excess of 270 kg over or across a boulevard including any curb, sidewalk or ditch unless such has been constructed or improved to form a suitable crossing, except when in use to improve or maintain the boulevard or in any area of the City within the Agricultural Land Reserve or a Rural Zone.
	9.	Construct a boulevard crossing, including a curb, ditch or sidewalk crossing.

SECTION 10 - CONDITIONS OF DIRECTOR'S PERMISSION

PERMIT FEE	1.	The Director may issue a permit in the form prescribed in
------------	----	---

Schedule 'F' to this Bylaw to do those things otherwise prohibited by Section 9 of this Bylaw.

- DEPOSIT 2. As a prerequisite to the issuance of a permit under this Section, the applicant shall, if required by the Director, deposit with the City a sum of money, or irrevocable Letter of Credit from a Chartered Bank of Canada if the amount is greater than Five Hundred Dollars (\$500.00) sufficient to pay for the cost of repairing any damage likely to be done to the highway, and as sufficient security that the obligations imposed by the permit are fulfilled within the time specified by the permit and where applicable one (1) years maintenance.
- DEFAULT 3. Failure by the permit holder to repair damage and/or fulfil such obligations as are set out in the permit within the specified time, shall enable the City to carry out the repair or fulfil the obligations that have not been met under the terms and conditions of the permit and to deduct the cost thereof from the monies on deposit or to call on the irrevocable Letter of Credit and to pay the costs therefrom and should there be an insufficiency of monies on deposit or through the Letter of Credit then the Permittee shall pay the balance forthwith upon invoice of the City or should there be a surplus of funds over and above that required by the City to carry out the works or fulfil the obligation such balance shall be paid to the Permittee.
- PLANS 4. The applicant shall provide, in triplicate, satisfactory plans and/or specifications of the work to be undertaken and when such are supplied and approved by the Director and the necessary permit issued, the work shall conform in every way to the plans and specifications so provided.
- SIGNING 5. Any person doing work on or in any highway shall provide and place appropriate barricades, lights and other safety devices as are required to protect the public.
- INSURANCE 6. The applicant shall provide evidence satisfactory to the Director that he is insured against all claims for damages for personal injury and property damage which may arise out of the performance of the work covered by the permit in an amount not less than Two Million Dollars (\$2,000,000.00) for each occurrence and if deemed necessary by the Director, the City shall be added to the policy as a co-insured.

- | | | |
|-------------------|----|---|
| MATERIALS | 7. | The applicant shall provide evidence satisfactory to the Director that all materials, labour and equipment which are needed to complete the work with reasonable dispatch are available. |
| AS-BUILT | 8. | The applicant shall provide the Director, following completion of the work, with a plan showing the works installed by the applicant if works are installed by the applicant, and such plan shall be drawn to a scale satisfactory to the Director showing the location, size and description of the works and the date of installation. The plan shall be supplied prior to the return or refund of any deposit or security posted as a condition of the permission. |
| UTILITY COMPANIES | 9. | The Director may issue a permit to a company regulated under the Utilities Commission Act permitting such company, over the calendar year for which the permit is applicable, to carry out such work as may be necessary in the case of an emergency, to repair any break or damage to the utilities under their control and subject to the terms of any franchise or other agreement entered into between such Utility and the City of Penticton. |

SECTION 10A - SIDEWALK CAFÉ PERMITS AND LICENCE AGREEMENTS

- | | | |
|--------------|----|---|
| PERMITS | 1. | The Manager of Regulatory Services may issue a Permit in the form prescribed for that purpose to authorize the use of a Highway for a Sidewalk Café, provided that the use complies with this section. |
| FEES | 2. | An applicant for a Permit under this section must pay to the City an annual Permit fee as set out in the Fees and Charges Bylaw. |
| AGREEMENT | 3. | Each applicant for a Permit must enter into a licence agreement with the City in the form of Schedule “K”, must carry the insurance required by the terms of the agreement, and must provide evidence of such insurance in accordance with the terms of the agreement. |
| TYPE 1 CAFÉS | 4. | A Type 1 Sidewalk Café must not occupy more than one-half the width of the Sidewalk abutting the premises of which it forms a part, or leave less than 1.5 metres (4.9 feet) of clear, unobstructed Sidewalk for Pedestrian use, except that in the case of a Sidewalk Café that was constructed prior to |

March 21, 2011 leaving a lesser Sidewalk width, the unobstructed width of Sidewalk may be such lesser width, but not less than 1.21 metres (4 feet) up to and including January 1, 2014.

TYPE 2 CAFÉS 5. The Manager of Regulatory Services must not issue Permits for Type 2 Sidewalk Cafés so as to authorize the occupation of more than eight parking spaces in a Block Face. Holders of Permits for Type 2 Sidewalk Cafes in the preceding year shall have priority for the issuance of such Permits in the subsequent year, provided that they apply for the Permit by February 28 of the subsequent year.

STANDARDS 6. The design and construction of Sidewalk Cafés that may be authorized by Permit under this section must comply with the standards and specifications set out in Schedule L, except that in the case of a Sidewalk Café that was constructed prior to March 21, 2011 with a sidewalk deflection geometry greater than 45 degrees or width of less than 1.5 metres (4.9 feet), the existing geometry and unobstructed width of a temporary sidewalk may be such lesser width, but not less than 1.21 metres (4 feet), up to and including January 1, 2014.

REVOCAATION 7. The Manager of Regulatory Services may, in writing, revoke a Permit issued under this section if the Sidewalk Café Permit Holder fails to remedy any breach of the Permit or the licence agreement of which the Manager has given notice, and thereafter the provisions of this bylaw, including the prohibitions in section 9 and the removal provisions in section 5, shall apply in full in respect of the Highway area for which the Permit was issued.

SECTION 10B SIDEWALK SALES OR SEATING AREA PERMITS AND LICENCE AGREEMENTS

PERMITS 1. The Manager of Regulatory Services may issue a Sidewalk Sales or Seating Area Permit in the form prescribed for that purpose to authorize the use of a Sidewalk for a Sidewalk Sales or Seating Area, provided that the use complies with this section.

FEES 2. An applicant for a Sidewalk Sales or Seating Area Permit under this section shall pay to the City an annual Permit fee as set out in the Fees and Charges Bylaw.

- AGREEMENT 3. Each applicant for a Sidewalk Sales or Seating Area Permit must enter into a Sidewalk Sales or Seating Area Licence Agreement with the City in the form of Schedule “M”.
- BENEFIT OF USE 4. A Sidewalk Sales or Seating Area shall only be for the use and benefit of a Person that holds a valid Business Licence to operate a Business on Commercially Zoned Property that is directly adjacent to the Sidewalk Sales or Seating Area.
- SIDEWALK AREA 5. A Sidewalk Sales or Seating Area shall be limited to the use of the inside portion of the Sidewalk as described in Schedule “N” – Sidewalk Sales Area Specifications or Sidewalk Seating Area Specifications.
- SUSPENSION 6. The Manager of Regulatory Services, if of the opinion that circumstances warrant it, may suspend and Sidewalk Sales or Seating Area Permit if the Sidewalk Sales or Seating Area Permit holder fails to remedy any breach of the Sidewalk Sales or Seating Area Permit or the Sidewalk Sales or Seating Area Licence Agreement in accordance with the respective terms thereof, and thereafter the provisions of this bylaw, including the prohibitions in Section 9 and the removal provisions in Section 5, shall apply in full in respect of the Sidewalk Sales or Seating Area for which the Sidewalk Sales or Seating Area Permit was issued and shall forthwith report such a suspension to Council stating the reasons therefore.
- REVOCAION 7. Any Sidewalk Sales or Seating Area Permit may be revoked by resolution of Council at any time, for any reason, and upon such notice, as it may deem advisable.

SECTION 11 - TRAFFIC CONTROL DEVICES

- ARTERIAL HIGHWAYS 1. The provisions of this Section do not apply to arterial highways.
- TRAFFIC 2. The Public Works Manager by himself or anyone under his direction is hereby authorized and empowered by order to place, replace or alter traffic control devices at any location he may determine to give effect to the provisions of the Motor Vehicle Act and this bylaw.

Such traffic control devices shall include all signs contained in B.C. Reg. 26/58 as amended from time to time without limiting the generality of the foregoing shall also include:

- | | | |
|-------------------|----|---|
| SIDEWALKS | a) | signs to regulate, control or prohibit pedestrian traffic, ridden or herded animals, vehicular traffic, cycle traffic, and traffic by other conveyances, either singly or together on sidewalks, bridges, walkways, or boulevards or in lanes; |
| STOP | b) | signs to regulate, control or prohibit the stopping of vehicles; |
| PARKING | c) | signs for the regulation, control or prohibition of standing or parking of vehicles; |
| PUBLIC BUILDING | d) | Signs to set apart and allot portions of highways adjacent to Federal, Provincial or Municipal public buildings for the exclusive use of Officials and Officers engaged therein for the parking of vehicles and the regulation of such parking. |
| MEN WORKING | e) | signs where construction, reconstruction, widening, repair, marking or other work is being carried out indicating that men or equipment are working upon the highway; |
| CONSTRUCTION ZONE | f) | signs where construction, reconstruction, widening, repair, marking or other work is being carried out to regulate or prohibit traffic in the vicinity of such works; |
| PEDESTRIANS | g) | signs to regulate or prohibit pedestrian traffic on highways other than at crosswalks; |
| SKATES | h) | signs to regulate, control or prohibit persons using roller skates, sleighs, skates, skis or other similar means of conveyance; |
| TURN PROHIBITION | i) | signs at intersections and in advance of intersections where it is required to prohibit certain movements; |
| DO NOT ENTER | j) | signs at the end of one-way roadways to prevent traffic entering the restricted area; |
| ONE-WAY | k) | signs on highways upon which the traffic is required to |

		travel in one direction only;
TWO-WAY	l)	signs at the transition from one-way to two-way roadways to indicate that normal travel is restricted to the right hand side of the roadway;
DO NOT PASS	m)	signs at the beginning of a zone through which restricted sight distance makes overtaking and passing hazardous;
KEEP RIGHT	n)	signs within and at the end of median strips and traffic islands;
LOADING ZONES	o)	signs at locations where due to adjacent commercial facilities it is desirable to reserve space for loading and unloading vehicles;
TRUCK SIGNS	p)	signs in locations where truck traffic is prohibited or restricted;
MAXIMUM WEIGHT	q)	signs at locations where due to seasonal weakening of road surfaces, obsolescence of bridges or pavements, or roadway repairs, loads in excess of those prescribed on the signs constitute a hazard to traffic or excessive damage to the roads;
MAXIMUM SPEED	r)	signs at locations where due to limitations of sight distances, road surfaces, traffic flows and frequency of intersections, speeds in excess of those prescribed on the signs constitute a hazard to traffic or excessive damage to the roads;
PASSENGER ZONES	s)	signs at locations where a bus or other transit vehicle stops to pick up passengers and it is desirable to restrict stopping, standing and parking to such vehicles;
NO STOPPING	t)	signs at locations where free flow of traffic is required for the roadway;
SCHOOL	u)	signs at locations where it is required to give advance information such as the presence of a school adjacent to a roadway, a school crosswalk, a school maximum speed zone;

PLAYGROUND	v)	signs at locations where it is required to give advance information of a playground adjacent to a roadway, or its maximum speed zone;
CROSSWALK	w)	signs or lines at locations where heavy pedestrian traffic crosses a roadway and at locations other than an intersection, such as at schools, playgrounds and public buildings where it is required to control pedestrian traffic;
ANGLE PARKING	x)	signs or lines in locations where it is permissible to angle park;
WARNING	y)	signs at locations where it is required to warn traffic of hazardous conditions, either on or adjacent to the roadway or prohibit traffic from using the roadway;
TRAFFIC SIGNALS	z)	at intersections and other locations where traffic signs are not adequate to control traffic efficiently;
TRUCK ROUTES	aa)	signs on streets where the Public Works Manager has designated truck routes for movement of truck traffic through the City;
NO PASSING	bb)	signs at locations approaching crosswalks, school and park zones indicating that passing is prohibited.
TAXI ZONES	cc)	signs at locations where due to frequent use by the public it is desirable to reserve a place for taxicabs only to stop, stand or park to pick up fares.
DANGEROUS GOODS	dd)	signs on highways where the Public Works Manager has designated dangerous goods routes for the movement of dangerous goods through the City.
PARKING FOR DISABLED	ee)	signs on highways to restrict parking to vehicles displaying a disabled person placard.
ORDERS	3.	The Public Works Manager in the exercise of his powers granted in 2. above, shall issue a written order directing that such thing be done. Such order shall be dated and signed by the Public Works Manager and a copy filed with the Clerk. A single order may contain any number of orders related to the matter set out in 2. above. The public Works Manager may issue orders under this Section as a sign record card in the

form of Schedule H.

- CHANGE 4. The Public Works Manager may rescind, revoke, amend or vary any order made by him provided such order does not require the doing of any act contrary to or inconsistent with this Bylaw of the Motor Vehicle Act.
- CONTROL 5. The Public Works Manager may order the alteration, repainting, tearing down, or removal of any sign, advertisement, or guide-post erected or maintained on or over any highway and in the exercise of this authority no compensation shall be paid to any person for loss or damage resulting from the alteration, repainting, tearing down, or removal of any sign, advertisement or guide-post placed upon or over any highway.
- TEMPORARY "NO PARKING" 6. The Public Works Manager, the Electrical Superintendent, the Fire Chief, the Chief of Police, or any Peace Officer or Bylaw Enforcement Officer may place or cause to be placed temporary "No Parking" signs or other applicable traffic control devices on a highway:
- a) along the route of any parade;
 - b) in the vicinity of a large gathering or during special circumstances;
 - c) to facilitate the fighting of fires;
 - d) to facilitate the clearing of snow, cleaning, repairing, excavating, decorating or other work upon a highway being carried out by the City or any other Utility;
 - e) in the interest of public safety.
- HIGHWAY SIGNS 7. Where traffic control devices have been authorized and placed under the provisions of the Motor Vehicle Act by the Ministry of Highways and Public Works of the Province of British Columbia, the same shall be deemed to have been properly placed or erected pursuant to the provisions of this Section.
- M.V.A. REGULATIONS 8. Traffic control devices erected pursuant to this Section shall, where applicable, comply with the sign regulations as set out in the Regulations to the Motor Vehicle Act.

SECTION 12 - VEHICLE REGULATIONS

This Section does not apply to arterial highways.

A. Prohibitions

Except as authorized by a permit issued by the Public Works Manager pursuant to Section 10 of this Bylaw, no person shall drive or operate on a highway:

- | | | |
|-----------------------------|----|---|
| MAXIMUM WIDTH | 1. | A passenger vehicle so loaded that any part of the load extends beyond the sides of the vehicle or more than 185 cm beyond the back of the vehicle. |
| PNEUMATIC | 2. | A vehicle, other than a horse-drawn vehicle, the wheels of which are not equipped with pneumatic tires in good order. |
| SOLID TIRES | 3. | A vehicle equipped with solid tires, the thickness of which between the rim of the wheel and the surface of the highway is less than 32 mm. |
| SPIKES, CLEATS, ETC. | 4. | A vehicle having wheels, or tracks constructed or equipped with projecting spikes, cleats, ribs, clamps, flanges, lugs, or other attachments or projections which extend beyond the tread or traction surface of the wheel, tread, or track but excluding tire chains of reasonable proportions when required for safety and winter studded tires between October 1st and April 30th. |
| SPEED SOLID TIRES | 5. | A solid rubber tired vehicle at a greater rate of speed than 20 km/hr. |
| SPEED UNLOADED POLE-TRAILER | 6. | An unloaded vehicle and pole-trailer at a greater rate of speed than 60 km/h unless the pole-trailer is carried on the towing vehicle. |
| LOAD | 7. | A vehicle unless it is so constructed and loaded as to prevent any of its load:

a) from shifting or swaying in such a manner as to affect the operation of the vehicle; or

b) from dropping, shifting, leaking, or otherwise escaping therefrom, but sand may be dropped for the purpose of securing traction, and water or other substance may be sprinkled on a roadway in cleaning or maintaining the roadway. |

8. A vehicle with any load unless the load and any covering thereon is securely fastened so as to prevent the covering or load from becoming loose, detached, or in any manner hazardous to other users of the highway.
9. No person shall drive or operate a vehicle on a highway while the vehicle is carrying a load of aggregate material if any of the load is likely, if not covered, to bounce, blow or drop from the vehicle in transit, unless
 - (a) the load is covered in a way that prevents any of it from blowing, bouncing or dropping from the vehicle, and
 - (b) the cover is securely and tightly fastened so that it is not, and cannot become a hazard.

B. Size & Weight Regulations

1. Application

- a) Subsections 2 to 7, inclusive, shall apply in respect of highways in the City except arterial highways.
- b) Subsections 2 to 7, inclusive, shall not apply to a commercial vehicle engaged in construction of, and operating within the limits of, a highway construction project, as established or as posted by the Ministry of Highways and Public Works or the City.
- c) Subsection 2 shall not apply to:
 - i) an implement of husbandry temporarily operated upon a highway during the hours of daylight;
 - ii) a vehicle operated by the Ministry of Highways and Public Works or the City engaged in road maintenance or snow removal.
- d) The weight limitations imposed by this Section shall not apply to vehicles operated by the Ministry of Highways and Public Works or the City while engaged in dropping or distributing material on the highways for the purpose of improving traction.

2. Size and Load

- a) Dimensions of vehicle and load:

No person shall, without a permit issued pursuant to this Bylaw, drive or operate on a highway:

- i) a vehicle having a total outside width, with or without load, in excess of 2.6 m, except that with loads of loose hay, loose straw, or loose fodder, the load may project over the side of the vehicle such distance as results in a total outside width not in excess of 3.1m;
 - ii) a vehicle having a height, with or without load, in excess of 4.2 m;
 - iii) a single vehicle having an overall length, with or without load, in excess of 11 m, except as provided in Subsections iv), v) and vi);
 - iv) a trailer the overall length of which exceeds 12.5 m, except that in the case of a "reefer-van" the overall length may be extended to include the refrigeration and/or heating unit only;
 - v) a semi-trailer the overall length of which exceeds 14 m, except that in the case of a "reefer-van" the overall length may be extended to include the refrigeration and/or heating unit only;
 - vi) a bus the overall length of the structure of which exceeds 12.5 m;
 - vii) a combination of vehicles having an overall length, with or without load, in excess of 20 m, except as provided in Subsections viii) and ix);
 - viii) a combination of three vehicles consisting of a 3-axle tandem drive truck-tractor, semi-trailer and trailer, or a 3-axle tandem drive truck-tractor and two semi-trailers, having an overall length, with or without load, in excess of 22 m, provided that the distance from the kingpin of the first semi-trailer to the extreme rear of the second trailer or semi-trailer and/or its load does not exceed 16.75 m;
 - ix) a combination of vehicles carrying a load on non-reducible logs, poles or piling in excess of 21.5 m.
- b) Notwithstanding any of the provisions of these regulations or a permit issued pursuant to these regulations, the maximum height, length, or width of a vehicle or load allowable on a highway or portion of a highway that is expressly limited as to maximum height, length or width of a vehicle or load by a sign erected by the Public Works Manager shall be that set out on the sign.
- c) Notwithstanding any of the provisions of these regulations, no person shall, without a permit issued pursuant to this Bylaw, drive or operate:

- i) on a highway a combination of vehicles consisting of more than two (2) vehicles; but if the gross vehicle weight of a combination of vehicles exceeds 11,000 kg, the combination of vehicles may consist of not more than three (3) vehicles;
- ii) on any highway a vehicle or combination of vehicles any part of which or the load of which extends more than 1 m beyond the front wheels thereof, or, if equipped with a front bumper, more than 1 m beyond such bumper;
- iii) on any highway a vehicle or combination of vehicles any part of which, or the load upon which, extends more than 5 m behind the centre of the last axle of the vehicle or combination of vehicles;
- iv) on any highway a semi-trailer having any portion of its body or load forward of the turning axis (kingpin) projecting to a greater distance than a radius of 2.25 m from the centre of the turning axis;
- v) on any highway a truck, truck-tractor, trailer, or semi-trailer having attached thereto a group of three (3) consecutive axles, unless one of the axles is a steering axle or an axle that is articulated in the manner of a steering axle and prevents any lateral movement between the road surface and the tires on the wheels attached to that axle when the vehicle is turning;
- vi) on a highway a truck, truck-tractor, trailer or semi-trailer having attached thereto any group of two (2) axles the centres of which are more than 185 cm apart, measured longitudinally, unless one of the axles is a steering axle or an axle that is articulated in the manner of a steering axle and prevents any lateral movement between the road surface and the tires on the wheels attached to that axle when the vehicle is turning;
- vii) Clause iii) of Subsection c) shall not apply to a logging truck-tractor and pole trailer carrying logs or poles in their natural state; such vehicles may be allowed a rear projection not to exceed 8.25 m from the centre of the last axle of the combination of vehicles;
- viii) Clause v) of Subsection c) shall not apply to trailers or semi-trailers:
 - A) having a group of three (3) or more axles, the centres of which are less than 106 cm apart; provided
 - B) the distance from the first axle of the group to the last axle of the group does not exceed 185 cm;
 - C) notwithstanding the provisions of Subsection 3, the maximum gross weight that may be carried on such a group of axles referred to in Clause A and B shall not

exceed 13,700 kg.

- d) Unless expressly permitted by the conditions of a permit, no person shall drive or operate an oversize vehicle or load on a Sunday or general holiday.
- e) When a commercial vehicle, trailer, or semi-trailer is equipped with:
 - i) one or more rear-view mirrors required by the regulations made pursuant to the Motor Vehicle Act and extend in whole or in part beyond the side of the vehicle, or
 - ii) one or more lamps required by the regulations made pursuant to the Motor Vehicle Act and extend in whole or in part beyond the side of the vehicle, or
 - iii) rubber fender skirts, safety chains, or wrappers which extend not more than 5 cm in whole or in part beyond the side of the vehicle.

the amount of such extensions shall not be included in determining the maximum width of the vehicle for the purpose of these regulations.

3. Weight

- a) No person shall, without a permit issued pursuant to this Act and regulations, drive or operate upon a highway:
 - i) a vehicle any axle of which is carrying a gross weight in excess of 9,100 kg;
 - ii) a vehicle loaded in such a manner that the gross weight on any wheel thereof is in excess of 110 kg per 1 cm of width of tire in the case of pneumatic tires of 55 kg per 1 cm of width of tire in the case of metal or solid rubber tires;
 - iii) a vehicle or combination of vehicles having a gross weight on any group of two or more consecutive axles exceeding the gross weight indicated in Schedule 2 opposite to the appropriate distance between the centres of the first and last axle of the group of axles of that vehicle or combination of vehicles measured longitudinally to the nearest distance as set out in the Schedule;
 - iv) a vehicle or combination of vehicles carrying a gross weight on the drive axle or axles that is less than twenty percent (20%) of the gross vehicle weight of the vehicle or combination of vehicles.

SCHEDULE 1

Distance Between the Centres of the First Axle and the Last Axle of Any Group of Axles of a Vehicle or Combination of Vehicles

Maximum Allowable Gross Weight on That Group of Axles

<u>cm</u>	<u>kg</u>
120.....	16,000
150.....	16,500
180.....	17,000
210.....	17,500
240.....	18,000
270.....	18,500
300.....	19,000
330.....	19,500
360.....	20,000
390.....	20,500
420.....	21,000
450.....	21,500
480.....	22,000
510.....	22,500
540.....	23,000
570.....	23,500
600.....	24,000
630.....	24,500
660.....	25,000
690.....	25,500
720.....	26,000
750.....	26,500
780.....	27,000
810.....	27,500
840.....	28,000
855.....	28,000

- 1) for the purpose of determining the maximum allowable gross weight of a vehicle or combination of vehicles, only those axles that are within the maximum overall length authorized under this Section shall be included;

- 2) Notwithstanding Subsection 1, where a vehicle or combination of vehicles is extended beyond the maximum overall length authorized under this Section for the sole purpose of accommodating an oversize or overweight load without any increase in the number of axles, the displaced axles shall be deemed to be within the maximum overall length authorized under this section.
 - b) In these regulations, in measuring the distance between the centres

of any group of axles where the distance is found to be equal to a number in Schedule 1 plus exactly 15 cm, the next higher number shall be used.

- c) Where a vehicle, or combination of vehicles, has a gross weight or a gross axle weight in excess of those gross weights fixed by these regulations, a Peace Officer or Bylaw Enforcement Officer, or any person authorized by the Public Works Manager, may permit the driver to proceed if the amount of excess gross weight does not exceed the following:

	<u>kg</u>
Single Axle.....	500
Combination of Vehicles.....	1,500

No person shall receive permission under this Subsection on a habitual or consistent basis.

- d) Redistribution - Where the load of a vehicle or combination of vehicles does not exceed the excess gross weight set out in Subsection 3 and the load may be redistributed upon the same vehicle and, forthwith after the weight of the vehicle under the authority of this Bylaw and regulations, the load on the vehicle is redistributed so that the limits imposed by these regulations are complied with, the requirements of this Section shall be deemed to have been complied with.
- e) Bridges - Notwithstanding any of the provisions of these regulations, no person shall, without a permit issued pursuant to this Bylaw and regulations, drive or operate over a bridge a vehicle or combination of vehicles having a gross weight on any axle or group of axles or a gross vehicle weight in excess of any load limit imposed by the Public Works Manager on that bridge.

4. Combination of Vehicles

- a) Notwithstanding the provisions of these regulations, no person shall drive or operate on a highway a combination of vehicles licensed for a gross weight in excess of 35,400 kg unless:
 - i) the towing vehicle has at least two (2) drive axles; and
 - ii) the gross weight to gross horsepower ratio of the towing vehicle bears a relationship of not more than 136 kg to 1

horsepower; but, if the gross horsepower of the towing vehicle exceeds 249 horsepower of a ratio that is within 25 horsepower of the ratio required under this Section shall be deemed to be in compliance with this Section.

- b) Clause ii) of Subsection a) shall not apply to a towing vehicle:
 - i) driven or operated under the authority of an overload permit;
 - ii) equipped with a gasoline powered engine, provided the towing vehicle is not licensed in excess of 37,200 kg and the engine has a net horsepower rating of at least 225 horsepower as determined by S.A.E. Standard J245.

5. Permit

- a) The Public Works Manager, by the issuance of a written permit in the form of Schedule "G", may authorize the driving or operation on a highway of a commercial vehicle that:
 - i) does not conform to Subsection 2 and the fee for the permit shall be in accordance with Schedule "G" of this Bylaw;
 - ii) does not conform to Subsection 3 and the fee for the permit shall be in accordance with Schedule "G" of this Bylaw.

CROSSOVE b) The Public Works Manager, may by the issuance of a written permit, authorize the crossing of a highway by a commercial vehicle that is overloaded or oversized, or both, and the fee for such a permit shall be in accordance with Schedule of this Bylaw. Highway crossing permits so issued shall be for the current licence year. Proof of public liability and property damage insurance must be produced before a permit will be issued.

PENALTY c) Any driver, operator, or owner of any vehicle or other person who violates any of the conditions contained in any permit issued pursuant to these regulations is guilty of an offence and is liable on summary conviction, to a fine of not more than \$500.00 or to a term of imprisonment not exceeding three (3) months, or both.

VARY d) The power to issue permits pursuant to this Bylaw shall include the power to amend, vary, or rescind such permits.

DEPOSIT e) As a prerequisite to the issuance of a permit under these regulations, the Public Works Manager may require the applicant therefor to deposit with the City a sum of money in an amount sufficient, in the opinion of the Public Works Manager, to pay the cost of repairing any damage that may be done to the highway, public structure or

bridge, by reason of the driving or operation of the vehicle thereon.

- DEPOSIT f) Where the term of the permit issued pursuant to Subsection a) extends beyond a single journey, the applicant shall deposit on account of the fee prescribed herein a sum of money equal to the estimated charges for the permit.
- OVERLOAD g) The fee to be charged for an overload permit under the Schedule shall be based on the total number of km of operation of the overloaded vehicle during the term of the permit.
- OVERSIZE h) An applicant for an oversize or overload permit may deposit with the
LOAD Public Works Manager a sum of money considered sufficient to secure the payment of the fees for such permits as may be required by the applicant and thereafter the applicant shall pay the permit fee forthwith on receipt of a bill from the City.
- REFUSAL i) Where an applicant fails to pay the fees charged under Subsection h), the Public Works Manager may refuse any further applications for permits, and may cancel any existing permits until such delinquent fees are paid.
- SINGLE j) No person may use a permit, other than a highway crossing permit, for the
VEHICLE driving or operation of a vehicle, other than the vehicle for which such permit was issued.
- TRIPS k) Where the term on an overload permits extends beyond a single journey, the permit holder shall, at the end of each calendar month, submit an accurate summary on forms provided by the City of the number of trips and the km of operation of the overloaded vehicle, and failure to do so shall be an offence.
- DISPLAY l) A permit issued under this Bylaw and regulations must be carried in the vehicle at all times when operating upon a highway.
- NOT m) No permit other than a highway crossing permit is transferable from one
TRANSFERABLE vehicle to another; but where a vehicle has been sold, destroyed, or exported from the Province, a substitute permit containing the same conditions as the original permit may be issued without fee and validated for the term of the original permit.

6. Restricted Route Permits

- a) The Public Works Manager, or a person authorized by him, may, by the issuance of a restricted route permit, in the form of Schedule "G", authorize the driving or operation of a vehicle or combination of vehicles carrying logs, or poles with or without bark, or saw timber cants, or hog fuel, or sawdust or pulpwood chips, subject to bridge load limits, and to the limitations or conditions contained in the permit, and provided that the applicant for the permit pays a fee as prescribed by Schedule for the additional weight allowed under the terms of the permit, which shall be the difference between the licensed gross vehicle weight and the maximum gross weight for which the permit has been issued, and further provided that the vehicle or combination of vehicles does not:
- i) have while carrying hog fuel or sawdust or pulpwood chips in a six axle combination of vehicles consisting of a truck or truck-tractor and a trailer or semi-trailer, any group of two axles the centres of which, measured longitudinally, are not less than 106 cm and not more than 165 cm with a gross weight in excess of 15,500 kg, or a single axle with a gross weight in excess of 8,625 kg, or a gross vehicle weight in excess of 45,000 kg;
 - ii) have while carrying logs or poles on a vehicle or combination of vehicles with 5 axles or less any group of two axles the centre of which, measured longitudinally, are not less than 106 cm and not more than 185 cm, with a gross weight in excess of 17,500 kg;
 - iii) have while carrying logs or poles on a vehicle or combination of vehicles consisting of 6 or more axles;
 - A) any single axle with a gross weight in excess of 9,100 kg;
 - B) any group of two axles the centre of which, measured longitudinally are not less than 106 cm and not more than 185 cm, with a gross weight in excess of 17,500 kg;
 - C) any group of 3 or more axles with a gross weight that exceeds Schedule 2 of this Section by more than 1,170 kg.
- b) Notwithstanding c) of Subsection 3 a vehicle or combination of vehicles transporting logs or poles may be permitted to proceed if the amount of excess gross weight does not exceed the following:
- i) during that period between March 2 and November 30 of any

one year

- A) Single Axle500 kg
- B) Tandem Axles1,100 kg
- C) Combination of vehicles1,500 kg

ii) during that period between December 1 of any one year to March 1 in the next year

- A) Single Axle500 kg
- B) Tandem Axles1,500 kg
- C) Combination of vehicles2,500 kg

iii) Clause 4 b) i) shall not apply to a vehicle or combination of vehicles operating under a Restricted Route Permit.

7. Weighing

a) Weighing and inspection of vehicles, driver to stop on direction - The driver of a vehicle on a highway, when so required by a Peace Officer or Bylaw Enforcement Officer or by any person authorized by the Public Works Manager shall:

- i) stop the vehicle at the time and place specified by such Peace Officer or Bylaw Enforcement Officer or authorized person for the purpose of weighing the whole or part thereof by means of stationary or portable scales, measuring the dimensions of the vehicle and load, measuring and inspecting the tires thereon, inspecting the load carried, or for any other purpose under this Bylaw;
- ii) drive the vehicle onto the nearest public or Department of Commercial Transport stationary or portable scales for the purpose of weighing the vehicle and load;
- iii) rearrange the load upon the vehicle or remove the whole or part of the load from the vehicle in order to comply with the provisions of this Bylaw, regulations, or permit before continuing to drive or operate the vehicle.

b) The drive of a vehicle on a highway, when directed by a traffic sign on the highway to drive over scales, shall drive the vehicle onto the scales for the purpose of weighing the whole or part thereof by means of stationary or portable scales, measuring the dimensions of the vehicle and load, measuring and inspecting the tires thereon, inspecting the load carried, or for any purpose under this Bylaw.

- c) Subsection b) does not apply to the driver of a commercial vehicle of a licensed gross vehicle weight not exceeding 5,500 kg.

C. Pilot Cars

1. Where conditions of an oversize or overload permit prescribe that pilot cars, signs, flags, or lights be provided by the Permittee, the standards for equipment as set forth in this Bylaw shall be complied with, unless otherwise prescribed by the conditions of the permit.
2. Pilot cars shall be private passenger motor vehicles or commercial vehicles of a licensed gross weight not exceeding 5,500 kg.
3. Signs required by a permit to be displayed on an oversized vehicle or load shall be as follows:
 - a) Sign panel size, 150 cm by 30 cm.
 - b) Black lettering on yellow background.
 - c) Letters shall be 20 cm in height of 3 cm stroke.
 - d) Shall contain only the words, "Wide Load" or in the case of loads only overlength, the words, "Long Load".
 - e) Mobile homes and modular buildings exceeding 3.4 m in width shall additionally display on the rear thereof a sign as follows:
 - i) yellow background with lettering of red reflective materials;
 - ii) letters shall be a minimum of 15 cm in height of a 3 cm stroke;
 - iii) shall contain the words, "Caution - May Slow or Stop Unexpectedly"
4. Every pilot car shall be equipped with at least one roof-mounted flashing amber lamp having a light source that will emit a beam of light clearly visible from a distance of 100 m in normal daylight, which shall be operated when the pilot car is escorting an oversize vehicle or load; except every pilot car escorting a load in excess of 3.5 m in width shall be equipped with a roof-mounted "Wide Load" sign of the following design:
 - a) Box shall be 180 cm by 35 cm by 10 cm mild steel. Outside surface shall be baked enamel (yellow). Inside surface shall be baked enamel (white) to give good reflective quality. Eight (8) lamps shall be mounted in the box, spaced to give even lighting of the sign background. This box shall shelter all wire connectors, switches, flashers, etc.
 - b) Sign shall be double faced of 3 mm yellow plexiglass background

with 28 cm by 4 cm black letters.

- c) Lamps shall have a rating of 12.5 volts, five (5) candle power, design amps three (3).
 - d) Mounted on top of this sign box shall be two (2) amber lamps (one at each end) of a two-way like design, of at least 17.75 cm in diameter which meets the C.S.A. standard B-106.1, 1972 flashing at 60-90 flashes per minute. This unit shall be designed to mount on car top carriers or equal mountings. It shall have two (2) positions, upright when in use and folded horizontally when not in use.
5. Flags on an oversize vehicle or load shall be red in colour, of a minimum size of 30 cm by 30 cm mounted on all four corners and (or) projections of the vehicle or load.
 6. If night travel of oversize vehicles or loads is authorized by permit, the extremities of the oversize vehicle or load shall be light in a manner not inconsistent with the provisions of Division 4 of the regulations made pursuant to the Motor Vehicle Act.
 7. No person shall drive or operate on a highway a motor vehicle or a commercial vehicle displaying a sign indicating the presence of an oversize vehicle or load when in fact, an oversize vehicle or load is not being transported or escorted.
 8. A pilot car when escorting an oversize vehicle or load on a two lane or three lane highway shall precede the oversize vehicle or load at a distance of not less than 100 m nor more than 500 m. When escorting an oversize vehicle or load on a four lane or divided highway, the pilot car shall follow the oversize vehicle or load at a distance of not less than 100 m nor more than 500 m.
 9. Notwithstanding Section 8, a lead pilot car shall, when necessary, precede the oversize vehicle or load through tunnels, structures, etc. at an adequate distance so as to provide ample warning for oncoming vehicles.
 10. Non-residents shall be deemed to have complied with these regulations, provided they are conforming to similar regulations that are in effect in the jurisdiction in which the vehicle is duly licensed and registered.
 11. Every person who drives or operates a pilot car in contravention of the provisions of this Bylaw is guilty of an offence.

SECTION 13 - PARADES

1. No person shall participate or take part in a parade unless such parade is under the direction and control of some person who has been issued a written permit for such parade by the Public Works Manager, and if the parade is on an arterial highway, a written permit has been issued to such person by the Ministry of Highways.
2. No parade shall be held unless application has been made in writing to the Public Works Manager by the person in charge, at least twenty-four (24) hours before the parade commences. Any application made under this Section shall specify the nature of the parade, day and hour on which such parade is to be held, the place or places of formation or commencement, the route intended to be taken and the point of disbandment.
3. The Public Works Manager may issue a permit for a parade upon receipt of an application in the form provided for in the last preceding Section, and may by such permit prescribe such terms and conditions as to place of assembly, time of assembly, route and time and place for disbandment of the parade as the Public Works Manager in his absolute discretion deems fit.
4. No person being the holder of a permit granted under this part shall fail to comply with any term or condition set forth in the permit.

SECTION 14 - REPEAL

The following bylaws are hereby repealed.

1. Traffic Bylaw, 87-56 and amendments thereto.

SECTION 15 - EXISTING TRAFFIC ORDER REMAIN IN EFFECT

All orders issued by the Public Works Manager under bylaw 3420 and amending bylaws including all sign record cards signed by him shall remain in full force and effect under this bylaw excepting only where such orders have been rescinded, revoked, amended or varied and in such event the Order as amended or varied shall be in full force and effect under this bylaw.

SECTION 16 - SEVERABILITY CLAUSE

If any section, subsection, sentence, clause or phrase of this Bylaw is for any reason held to be invalid by the decision of any Court of competent jurisdiction, the invalid portion shall be severed and the decision that it is invalid shall not affect the validity of the remainder.

READ A FIRST time this 16th day of May, 1994.
READ A SECOND time this 16th day of May, 1994.
READ A THIRD time this 16th day of May, 1994.
RECONSIDERED and FINALLY PASSED and ADOPTED
this 6th day of June, 1994.

Mayor

City Clerk

Certified a true copy of Bylaw
No. 94-39 as adopted.

City Clerk

SCHEDULE A

CITY OF PENTICTON TRAFFIC BYLAW 94-39

CITY OF PENTICTON

RENTAL OF PARKING METER HOODS (SPACES)

Requested By: _____

Address of Applicant: _____

Number of Days Hoods (Spaces) Required: _____

Date Hood(s) or Space(s) Required: _____

Number of Hoods (Spaces): _____

Meter Number(s)/Location of Space(s): _____

COST: (\$10.00 for 1st day per hood/space + G.S.T.) & \$6.00 per day thereafter

TOTAL _____ REC. # _____

Bylaw Enforcement Officer Notified: _____

Date Hoods Taken Off: _____

Hoods to be taken off meters when above days are reached unless additional payment is received.

Building & Licence Division

(BLDG FORMS METER FOR)
95/01/24



SCHEDULE B

CITY OF PENTICTON TRAFFIC BYLAW #94-39

APPLICATION FOR PARKING PERMIT

Applicant: _____

Address of Applicant: _____

Phone: _____

Parking area for which Permit Requested: _____

Parking Stall No: _____ Fee: \$20.00 per month - maximum six months.

Parking Permit Period: _____ Months, from _____ to _____

Deposit: _____

Receipt No.: _____

Application: Approved

Rejected

Public Works Manager

Notes:

1. This parking permit is not transferable
2. Unauthorized vehicles will be removed at permit holders request.

Job (for unschedB)

SCHEDULE C

THE CITY OF

 SCHEDULE C
 BYLAW
 No. 87-86 94-39

PARKING PERMIT

NO. _____

MAJOR _____

PLEASE NOTE

PLEASE PLACE THIS PERMIT IN THE RIGHT HAND CORNER OF THE DASHBOARD OF YOUR CAR. IT ENTITLES YOU TO FREE PARKING IN ANY METERED ZONES, AND IN HOURLY PARKING ZONES, BUT NOT IN LOADING ZONES, BUS STOPS, OR WHERE PARKING IS IN ANY WAY RESTRICTED. WE HOPE THAT YOU WILL PAY US THE COMPLIMENT OF VISITING OUR CITY AGAIN.

SCHEDULE D Revised (See following)

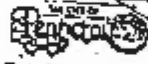
 CITY OF PENTICTON

PARKING EXEMPTION PERMIT

PURSUANT TO TRAFFIC BY-LAW No. 87-86 94-39

THE OPERATOR _____ (NAME)

OF VEHICLE _____ (LICENSE NO.) IS EXEMPT

FROM THE PROVISIONS OF THE SAID REGULATIONS

No. _____

PUBLIC WORKS MANAGER _____

SCHEDULE "D"

	CITY OF PENTICTON PARKING EXEMPTION PERMIT
PURSUANT TO TRAFFIC BYLAW NO. 94-39	
THE OPERATOR _____ (NAME)	
OF VEHICLE _____ IS EXEMPT	
FROM THE PROVISIONS OF THE SAID REGULATIONS	
NO. _____	_____
	PUBLIC WORKS MANAGER



SCHEDULE E

CITY OF PENITCTON TRAFFIC BYLAW # 94-39

APPLICATION FOR EXTRAORDINARY TRAFFIC AGREEMENT

Applicant: _____

Address of Applicant: _____ Phone: _____

Type of Extraordinary Traffic: _____

Proposed Route: _____

Date and Time: _____

Deposit: _____ Receipt No.: _____ Date: _____

Agreement Approved
 Rejected _____ Public Works Manager

I Assume responsibility for any damage or expense which in the opinion of the Public Works Manager has been caused by the above noted extraordinary traffic and agree I will pay the City of Penitcton for any and damage or expense.

Signature of Applicant _____

SCHEDULE F

CITY OF PETERBURGH TRAFFIC BYLAW # 87-56

Application to construct, use, and maintain works within a roadway or lane.

Name of Permittee (Company): _____

Address: _____

Attention: _____

Phone # _____

These proposed works are subject to the general conditions or noted special conditions as listed on this permit.

It is understood that the completion of this form constitutes an application only, and the works applied for will not commence until this permit has been approved.

Date of Application: _____

Signed: _____

The proposed works consists of and are described as follows:

Location of Works: _____

Drawing No.: _____

The plans submitted shall consist of a key-map, general plan-profiles, and where necessary, detail plans.

The drawings shall supply at least the following information:-

- (a) The legal boundaries of all road allowances or easements and adjacent legal lot descriptions.
- (b) The proposed utility position (horizontal and vertical) related to legal boundaries and any existing utility or surface features within the public right-of-way.
- (c) The details of all trench depths and backfill tanks, manholes, poles, boxes, bridges, culverts, walls, or other structures to be constructed, or standard drawing specifications where applicable.

SPECIAL CONDITIONS:

(COMPLETED BY CITY)

ESTIMATED SURFACE REPAIR COSTS: (BY CITY)

1. Asphalt Patching	\$	_____
2. Concrete Repairs	\$	_____
3. Other	\$	_____
Estimated Total	\$	_____

Any of the above conditions apply to this permit approval and nothing in the above is meant to abrogate the general requirements that all work must be in accordance with the City of Peterburgh Construction Specifications, being Schedule "A" attached to and forming part of the City of Peterburgh Subdivision Bylaw 4406, or in compliance with provincial or Federal regulations.

A cash deposit in the amount of \$ _____ shall be deposited with the Public Works Department to insure construction is in accordance with approved plans and this permit.

CITY OF PETERBURGH APPROVAL

Public Works Department
 171 MARSH STREET
 PETERBURGH, N.B.
 CANADA
 Y2A 6A0

Date: _____

19 _____

Copies of Approved Permit and Plans to:

-Applicant (Blue)

-Public Works Const. Inspector (Pink)

-Public Works File (White)



WILLIAM BRIDG
PENIKESE I.S.A.C.
CANADA
VIA SAO
TEL: 491-3054

PERMIT GENERAL CONDITIONS

D. NOTIFICATION/ROAD CLOSURES

- 1.-No work shall commence until the drawing and this permit have been approved by the Public Works Department and 3 prints of the approved drawings are received by the Public Works Department.
- 2.-a) prior to starting any work, a minimum of 48 hours notice in writing must be given to the Public Works Department.
-b) 24 hrs. notice for the required City assistance in locating existing services shall be given to the City's Works Division.
- 3.-Road Closures are not permitted without 24 hours notice given to the Public Works Department and Fire Dept. and approval of detour signing is required.
-Scheduling may be restricted with respect to summer traffic, bus routes, or other project coordination.
- 4.-Any existing utilities, electrical, water, and sanitary services, hydrants, valves, etc., shall be located prior to construction and shall remain accessible and usable at all times.

B. SUBFACE AND UTILITY REPAIRS

- 1.-Any damage to works or utilities including trees shall be reported immediately to the Public Works Dept. who may undertake repairs at the Applicant's expense or direct that the Applicant make the necessary repairs, with restoration equal to existing or to the satisfaction of the adjacent property owner.
- 2.-No underpinning under any existing concrete works is permitted. Replacement shall include cutting and complete removal of the total concrete section and any curb returns removed shall be replaced with standard wheel chair ramps.
- 3.-All pavement patching shall be hot-mix asphalt. All cuts through pavement shall be a straight line, approved by the Public Works Department prior to patching and shall be completed within 48 hours of excavation.
- 4.-No asphalt patching, or concrete repairs shall be done after October 30, without approval of the Public Works Department.
- 5.-Written approval shall be received by the Parks Supervisor for any work within 2.0m of the branch spread of any tree within the public road allowance.
- 6.-For any trench within the public road allowance, where the utility inverts are 1.0m or less, the backfill above the duct zone shall be 75mm minus crushed gravel to finished subgrade.

C. INSPECTION & ACCEPTANCE

- 1.-In the event that construction is contrary to the approval given by this permit, the applicant or utility owner shall correct the installation. Failure to comply with the requirements of this permit will give the City reason to order the applicant to stop work.
- 2.-The Applicant or owner of the utility shall place no liability on the City as a result of any damage arising out of this permit approval including a 1 year maintenance period.
- 3.-Within 3 months of the "Notice of Substantial Completion", the applicant shall submit an as-built drawing to the Public Works Department.
- 4.-Clean-up and dust control may require mechanical sweeping of all paved streets on a daily basis.
- 5.-Upon notice in writing of the intention on the part of the City to construct, extend, alter, or improve any public works, the utility owner for which this permit is granted shall coordinate with the City and within three (3) months from receipt of notice shall complete his relocation work as may be necessitated by the construction.



File: 5640.50

APPLICATION TO HOLD A SPECIAL EVENT

DATE: _____
ORGANIZATION NAME: _____
CONTACT PERSON: _____
PHONE #: _____
FAX #: _____
MAILING ADDRESS: _____

EVENT INFORMATION

EVENT NAME: _____
PARTICIPATING SPONSORS: _____

EVENT DATE: _____
START TIME: _____ FINISH TIME: _____
ANTICIPATED ATTENDANCE: _____

EVENT ROUTE COMPLETE WITH ANY ROAD OR LANE CLOSURES:
(A City Map is attached to assist with street names and route preparation)

INSURANCE REQUIREMENTS

Evidence of current liability insurance is required from an applicant proposing to use municipal streets, parks or facilities for special events.

The minimum liability insurance requirements are as follows:

1. 2,000,000 comprehensive General Liability policy with inclusive limits for bodily injury and property damage liability including coverage for participants;
2. Cross-liability clause;
3. Municipality named as an additional named insured;
4. 30 days prior written notice of cancellation or material change;
5. Executed copy of Certificate of Insurance, 10 days prior to the event.

Note the organizer should be advised that they are fully responsible to determine their own additional insurance coverage they may require, if any, including Workers Compensation, that are necessary and advisable for their own protection and/or fulfil their obligations in organizing the event including protection of the municipality.

ADDITIONAL INFORMATION

Included in this event will be:

	YES	NO
ALCOHOLIC BEVERAGES	<input type="checkbox"/>	<input type="checkbox"/>
FOOD PREPARATION	<input type="checkbox"/>	<input type="checkbox"/>
MERCHANDISE OR FOOD SELLING	<input type="checkbox"/>	<input type="checkbox"/>
TEMPORARY STRUCTURES (Stages, tents, etc)	<input type="checkbox"/>	<input type="checkbox"/>
ENTERTAINMENT	<input type="checkbox"/>	<input type="checkbox"/>

The application (Event Manager) will:

1. Be responsible for advising all attendees and will ensure that all attendees adhere strictly to all regulations posted and/or attached hereto. Failure to adhere to said regulations can result in this permit being revoked without refund of any fees paid.
2. Provide a competent and trustworthy adult who will personally undertake to be responsible for the due observance of regulations governing the Premise, Lands and Equipment.
3. Exercise the greatest care in use of the facility, lands and equipment and adjacent premises.
4. Be responsible for any damages incurred said damages to be paid firstly by the applicant and/or their insurer.
5. Use only the Premises, Lands and equipment named in this Agreement.
6. Not permit any other Group or Organization not named on this Agreement to use said Premises, Lands and Equipment without the authorization of the (City of Penticton).
7. Be responsible for leaving the Premises, Lands and Equipment clean. Failure to do so may result in an additional fee levied for maintenance.
8. Adhere to grass closure. Information may be obtained by calling (Name and Phone Number of Contact Person)
9. Not use grass fields, parks etc., when closure is in effect unless specific authorization has been given by the City of Penticton.
10. Not place objects in or on grass fields without first consulting with the Parks Department.
11. Call (Name of Contact and Phone Number) _____ and cancel the permit if you do not plan to use it.
12. Will not permit liquor or beer on any Premises unless a liquor permit is in effect. A copy of said permit shall be presented and attached to this agreement prior to use of said facility.
13. Pay all fees levied according to this agreement including but not limited to, costs associated to any breach of this agreement.



SCHEDULE G

CITY OF PENITCTION TRAFFIC BYLAW # 96-39

APPLICATION FOR OVERSIZE, OVERLOAD, OVERWEIGHT & RESTRICTED ROUTE PERMIT

Applicant: _____

Address of Applicant: _____

Phone: _____

Purpose: _____

Proposed Route: _____

Date and Time: _____ Make of Truck: _____

Licence No: _____ Overall Length: _____ Overall Width: _____

Licensed Gross Vehicle Weight: _____ Excess Gross Weight: _____

Specify Oversize Length: _____ Width: _____

Fees: _____ for Oversize Vehicle

_____ for Overload Vehicle

_____ for Overweight Vehicle

Application: Approved Rejected

Pilot Car Required: Yes No route road markers

I Assume responsibility for any damage or expense which in the opinion of the Public Works Manager has been caused by the above noted extraordinary traffic and agree I will pay the City of Penitction for any said damage or expense.

Signature of Applicant: _____



SCHEDULE H

CITY OF PENTICTON SIGN RECORD

N.O.I. _____ Date: _____ 19__

Sign Number _____ Size _____ Reflectorized _____

Description of Sign _____

Location _____

Requested by _____

PUBLIC WORKS MANAGER

Date Installed _____ Installed By _____

Traffic Order Updated _____ Field Checked _____

Drawings Updated _____

Return this form to the Public Works Department

CITY OF PENTICTON
 PUBLIC WORKS DEPARTMENT
 SCHEDULE 1
 BYLAW NO. 94-39

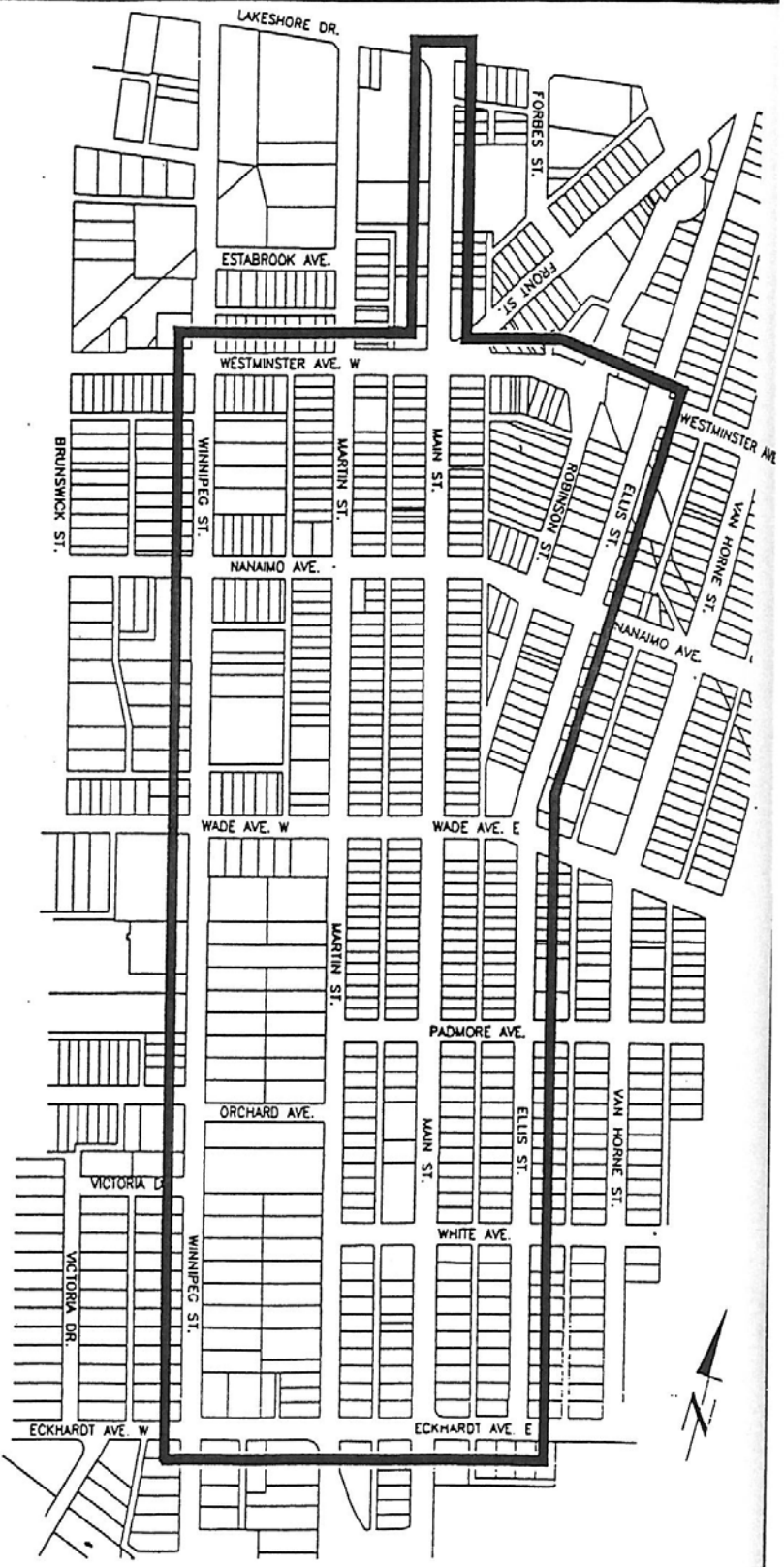

SCHEDULE “J”



RESIDENT PARKING ONLY PLACARD

SCHEDULE J

BYLAW NO. 94-39

This Placard is issued subject to Bylaw No. 94-39 and the City of Penticton Policy for Resident Parking Only Areas

This Resident Parking Only Placard is only valid for Resident Parking Only Area No. _____

To Be Valid This Placard must be hung from the rear view mirror of the vehicle. Alternatively where a vehicle is not equipped with a rear view mirror the Placard must be placed face up on the right, passenger side of the dashboard. Where this Placard is not displayed as described above or is not fully visible from the exterior of the vehicle, the Placard is not valid and the vehicle is therefore in violation of the RPO parking restrictions and may be ticketed.

SCHEDULE "K"

THE CORPORATION OF THE CITY OF PENTICTON

LICENCE AGREEMENT

NATURE OF AGREEMENT:

FILE:

SIDEWALK CAFÉ LICENCE

DATE:

PARTICULARS:

Type 1 Sidewalk Café _____, or;

Type 2 Sidewalk Café _____, number of parking stalls or parts thereof _____.

THIS AGREEMENT MADE the ____ day of _____, 20__

BETWEEN: THE CORPORATION OF THE CITY OF PENTICTON

171 Main Street, Penticton, B.C. V2A 5A9

(the "City")

OF THE FIRST PART

AND:

(the "Permit Holder")

OF THE SECOND PART

WHEREAS the Permit Holder applied for a Permit to operate a Type _____ Sidewalk Café (the "Permit") under the City's Traffic Bylaw, and the issuance of such a Permit is subject to the applicant entering into this Agreement;

NOW THEREFORE in consideration of the issuance of the Permit by the City authorizing the Permit Holder to conduct business on a Highway area belonging to the City, the Permit Holder agrees as follows:

In this Agreement, "Licence Area" means the area of City Sidewalk identified in Schedule A to this Agreement and the Permit, and terms with initial capitals not defined in this Agreement shall be interpreted in accordance with the City's Traffic Bylaw.

1. The City grants to the Permit Holder a licence to occupy the Licence Area for the purpose only of operating a Sidewalk Café, and only in accordance with the terms of this Agreement.
2. The right to occupy shall be for the calendar year ____ and, unless terminated pursuant to this Agreement, may thereafter be renewed annually for a subsequent calendar year, upon payment of the annual fees set out in section 10A of the City's Traffic Bylaw.
3. The Permit Holder agrees that the Licence Area shall not be used solely for the purpose of storage of fixtures, chattels or objects.
4. The Permit Holder shall display the Permit in the business premises in relation to which it was issued, in such manner as to be clearly visible to members of the public.
5. The Permit Holder shall use the Licence Area only in accordance with the terms of the Permit and any applicable City bylaws, and the Permit Holder shall permit the Manager of Regulatory Services to enter the Licence Area and the business premises to which it is appurtenant at any time, for the purpose of monitoring compliance with this Agreement and the Permit.
6. The right to use the Licence Area granted by the Permit and this Agreement is subject at all times to the right of the City and any public utility, and the employees and contractors of either of them, to enter the Licence Area without notice or reimbursement to the Permit Holder, for the purpose of installation, maintenance and repair of pavement, curb and gutter, Sidewalk, pipes, cables, conduits, wires, poles or any other service or installation permitted in a Highway.
7. The Permit Holder shall maintain the Licence Area and the adjacent pavement, Sidewalk and Boulevard in a clean and sanitary condition free from grease, papers, rubbish and debris, to the satisfaction of the Manager of Regulatory Services.
8. The Permit Holder shall maintain the improvements authorized by the Permit to be placed in the Licence Area in good condition, keeping all barriers, fences and temporary Sidewalks properly aligned, plumb and properly finished.
9. The Permit Holder shall not erect any buildings or structures in the Licence Area other than those specifically authorized by the Permit.

10. The Permit Holder shall vacate the Licence Area at the end of the term of this Agreement if the Agreement is not renewed, or upon the earlier termination of this Agreement if the Permit is revoked, by removing all fixtures, chattels and objects of the Permit Holder and making good any damage to the Sidewalk or Roadway caused by the installation or removal of fixtures.
11. The Permit Holder shall remove all fixtures, chattels and objects of the Permit Holder from the Licence Area when required to do so by a police officer, municipal bylaw enforcement officer, the Public Works Manager or the Manager of Regulatory Services so as to temporarily restore the use of the Licence Area as a Sidewalk or a Roadway.
12. The Permit Holder acknowledges that upon its failure to comply with section 10 or 11, the City may remove all fixtures, chattels and objects of the Permit Holder from the Licence Area and repair any damage at the Permit Holder's expense, and agrees to pay the City's costs of removal and, if necessary, storage of such materials and repair of damage, promptly on receipt of the City's account in that regard.
13. The Permit Holder further acknowledges that any fixtures, objects or chattels removed and stored by the City and not claimed within sixty days of removal shall become the property of the City, and may be sold and the proceeds retained by the City.
14. The Permit Holder acknowledges and agrees that the Licence granted by this Agreement does not permit the use of the Licence Area in any manner that would have the effect of blocking or impairing the entrance to any premises adjacent to the Licence Area.
15. The City shall not be liable directly or indirectly, for any personal injuries that may be suffered or sustained by any Person who may be in the Licence Area or for any loss or damage or injury to property belonging to the Permit Holder or any other Person and located in the Licence Area, unless such injury, loss or damage is due to the City's negligence or default, or negligence or default of those for whom the City is in law responsible.
16. The Permit Holder shall at all times indemnify and save harmless the City and its officials, officers, employees, servants and agents from all cost, losses, damages, compensation and expenses, including actual legal fees, of any nature whatsoever suffered or incurred by the City and caused or sustained by the Permit Holder's occupation or possession of the Licence Area, and from all claims, demands, suits and judgments against the City or its officials, officers, employees, servants and agents on account of or in respect of the Licence Area or the occupation or possession of the Licence Area by the Permit Holder, its servants, agents, contractors, or invitees.

17. The Permit Holder shall at its own expense provide and maintain comprehensive general liability insurance in the minimum amount of \$2,000,000.00 per occurrence against bodily injury and property damage, naming the City and its officials, officers, employees, servants and agents as additional insured's, and shall provide a certificate evidencing the insurance at the time of executing this Agreement and thereafter as required by the City. Such insurance shall contain provisions for cross-liability and severability of interest, and shall be endorsed to provide that the policy will not be changed in any way or cancelled until thirty days after written notice of such change or cancellation shall have been given to the City.
18. The Permit Holder shall not assign the right to use the Licence Area to any other person without the express written consent of the City, and any such assignment shall be in writing. In the event that the Permit Holder transfers its interest in the business premises abutting or adjacent to the Licence Area, the Permit Holder shall obtain the consent of the City to the assignment of the licence granted by this Agreement.
19. This Agreement does not exempt the Permit Holder from any obligations created by any bylaws of the City affecting the use of the Licence Area of the business premises to which the Licence Area is appurtenant, including without limitation any business bylaw, business licence bylaw, building bylaw, or sign bylaw.
20. If the Permit Holder shall be in default in performing its obligations under the Permit or this Agreement, the City may give written notice to the Permit Holder of such default giving the Permit Holder seven days to remedy such default, or such shorter time as the Manager of Regulatory Services may deem appropriate in circumstances constituting a hazard to the public, failing which the City may, by further written notice to the Permit Holder, immediately revoke the Permit and terminate the licence granted by this Agreement.
21. Any notice to the Permit Holder contemplated by this Agreement may be given to the Permit Holder at the address of the business premises to which the Licence Area is appurtenant.
22. This Agreement shall ensure to the benefit of and be binding upon the parties hereto and their respective heirs, executors, administrators, successors and permitted assigns, as the case may be.

IN WITNESS WHEREOF the parties hereto have hereunto executed this agreement as of the date and year first above written.

(Name of Permit Holder)

By its authorized signatory(ies):

Name:

Name:

THE CORPORATION OF THE CITY OF PENTICTON

Manager of Regulatory Services

SCHEDULE A TO LICENCE AGREEMENT

[PLAN OF LICENCE AREA]

Permit holder has provided the attached layout drawing of the Sidewalk Café Licenced Area and any detail drawings of all barriers, fences and decorations and detail drawings of the temporary or permanent sidewalk proposed for Type II Cafes.

SCHEDULE “L”

SIDEWALK CAFÉ SPECIFICATIONS

1. The applicant for a Sidewalk Café permit must submit a layout drawing of the Sidewalk Café (drawn to scale) indicating the building in which the business premises are located and any adjacent building, the entrances to those buildings, the width of the Sidewalk and locations of any obstructions such as trees, planters, fire hydrants or benches, the location and design of the Sidewalk Café and all proposed fences, barriers, tables, chairs or decorations. A detailed design of all barriers, fences and decorations must also be included. For Type 2 Sidewalk Cafés the design and layout of the Sidewalk in the road must also be included. The required specifications for particular components are set out in the attached drawing. The submitted drawings if approved by the Manager of Regulatory Services shall form Schedule – A of the Licence Agreement.
2. A Sidewalk Café may not extend onto the Sidewalk in front of adjacent business premises without the agreement of the proprietor of the business provided to the City in writing.
3. The applicant for a Sidewalk Café must submit a written explanation of the intended use of the Sidewalk Café including the services that will be offered to patrons of the Sidewalk Café.
4. New signage is not permitted without a sign permit issued under the Sign Bylaw.
5. The Sidewalk Café Permit Holder shall not erect on the Sidewalk or Roadway any buildings or structures other than approved fences, barriers and temporary Sidewalks.
6. Designs for Sidewalk Cafés and temporary Sidewalk structures should have a color scheme that complements that of the building containing the business premises; an architectural style that complements that of the building; utilize sturdy chairs and tables; and incorporate the use of flower baskets or boxes.
7. Temporary fences or barriers that surround the Sidewalk Café may be physically anchored or attached to City Sidewalk or Roadway surfaces in accordance with a method to be approved by the City. Repair of any penetrations or other damage to the City shall be the responsibility of the Cafe owner.
8. Sidewalks located on City Roadways shall include the following design features;
 - a. They must consist of Sidewalk sections formed in concrete with a non-slip finish and a minimum unobstructed width of 1.5meters (4.9 ft.). The sections

- must be flush with each other and with the curb and Sidewalk when installed, and contain no gaps or cracks including at the point where the Sidewalk section joins the curb, greater than 6 mm (1/4 inch).
- b. They must have a 1.07 meter (42 inches) high metal guardrail on the vehicular traffic side of the Sidewalk for the full length of the Sidewalk, including returns. The metal guard rail shall be constructed of 38 mm (1.5 inch) square material and consist of a top rail and a mid-height rail supported by vertical posts at maximum intervals of 1.8 meters (6 feet), all in accordance with the attached drawing.
 - c. The vehicular traffic side of the top rail must have reflective tape installed along its full length, including returns.
 - d. The installation must allow for the free flow of water along the gutter, by providing a clear space at least 152 mm (6 inches) wide immediately adjacent to the curb and at least 51 mm (2 inches) high.



CITY OF PENTICTON SIDEWALK CAFES

UNOBSTRUCTED
SIDEWALK ZONE

Type 1

BUILDING FACADE

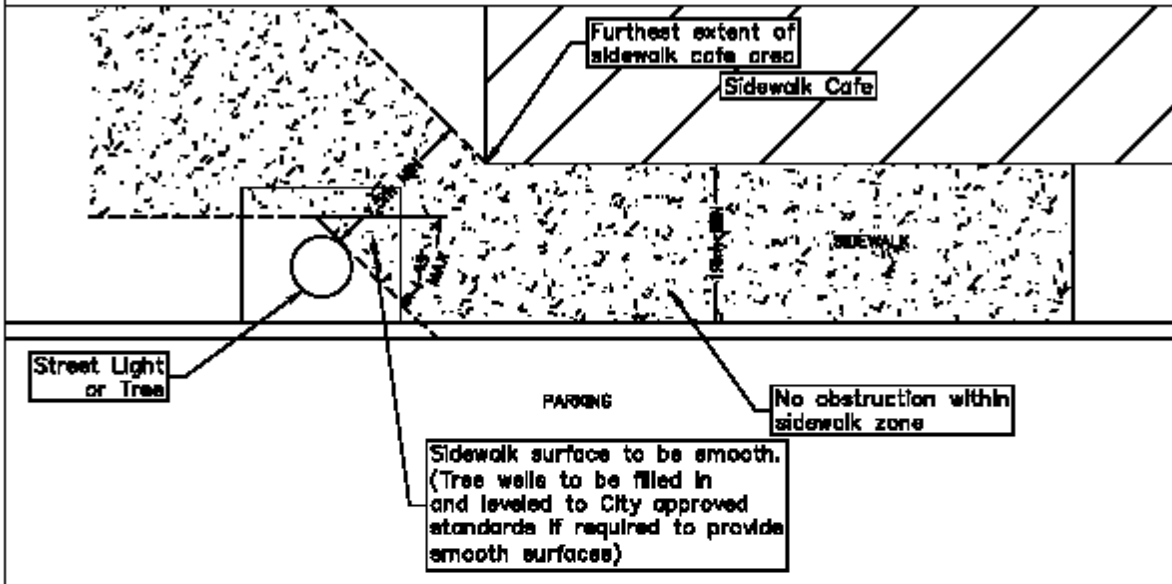

Type 2

BUILDING FACADE

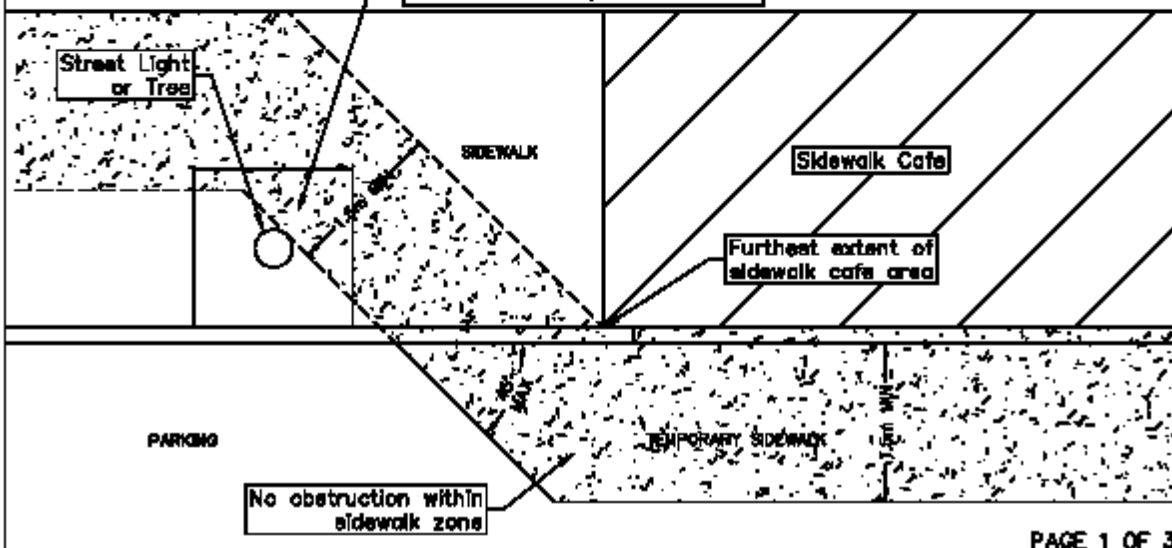



CITY OF PENTICTON SIDEWALK CAFES

CONSTRUCTION DETAILS

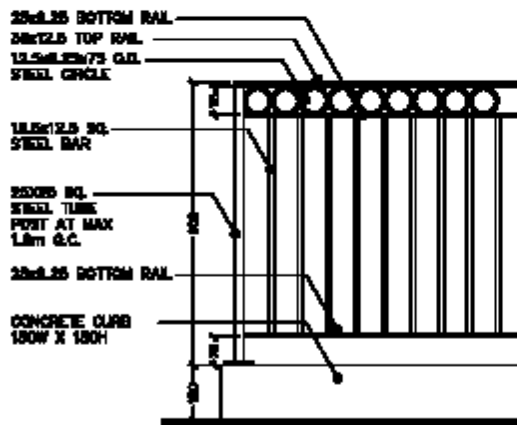
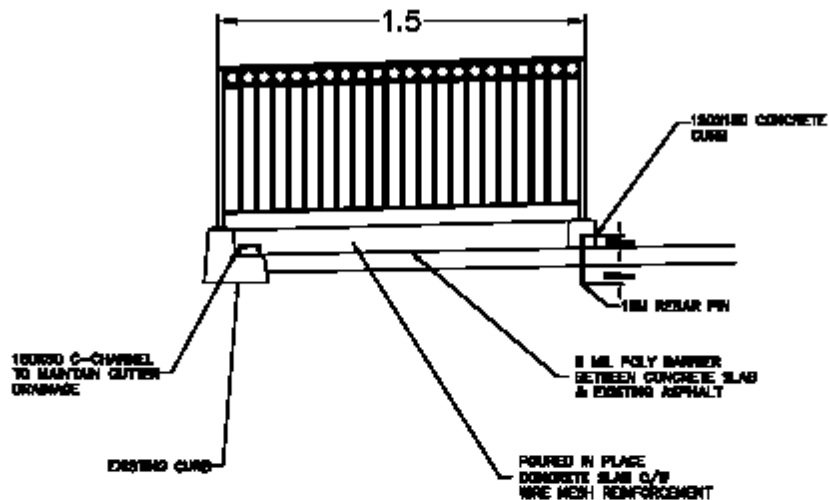

STEEL MOUNTING PLATE - 100x100x4.25; CENTER POST IN PLATE. ANCHOR WITH 10mm BY 50.0mm CONCRETE EXPANSION BOLT

BOLT HOLES OFFSET MIN 18mm FROM EDGE OF PLATE

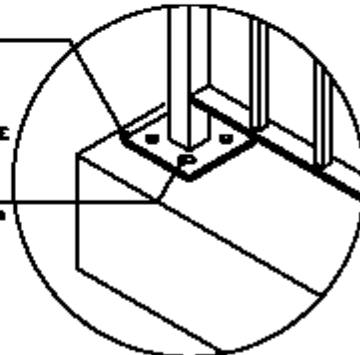

NOTE:
1. ALL JOINTS TO BE WELDED
2. FINISH WITH 2 COATS OF BLACK 2 PART RUST RESISTANT PAINT OR POWDER COAT

NTS

ISOMETRIC
NOT TO SCALE



CITY OF PENTICTON SIDEWALK CAFES

TYPE 2
CONCRETE BOARDWALK
DETAIL

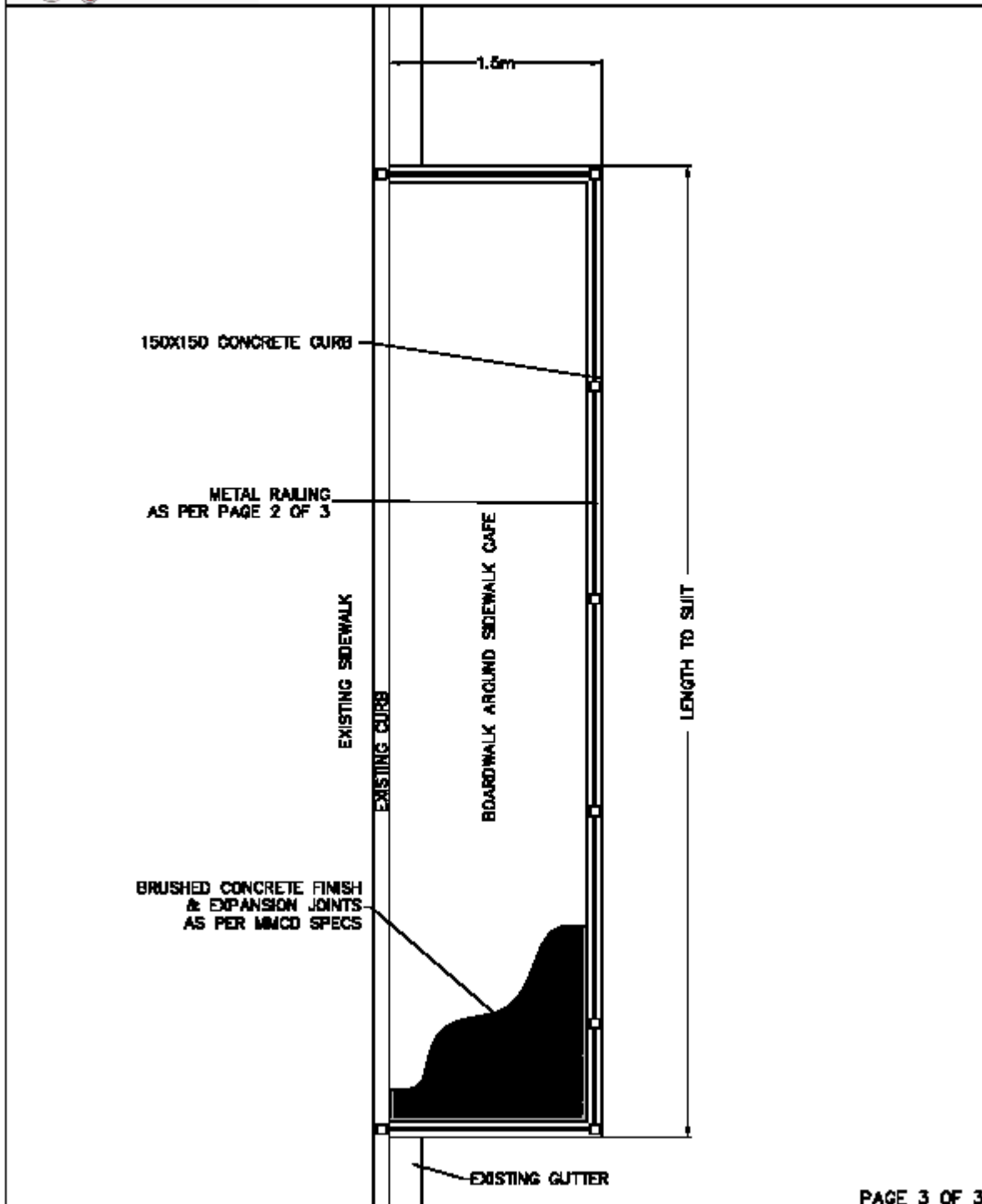

SCHEDULE "M"

THE CORPORATION OF THE CITY OF PENTICTON

LICENCE AGREEMENT

NATURE OF AGREEMENT:

FILE:

SIDEWALK SALES OR SEATING AREA

DATE:

THIS AGREEMENT MADE the ____ day of _____, 20__

BETWEEN: **THE CORPORATION OF THE CITY OF PENTICTON**

171 Main Street, Penticton, B.C. V2A 5A9

(the "City")

OF THE FIRST PART

AND:

(the "Permit Holder")

OF THE SECOND PART

WHEREAS the Permit Holder applied for a Permit to operate a Sidewalk Sales or Seating Area (the "Permit") under the City of Penticton Traffic Bylaw No. 94-39, and the issuance of such a Permit is subject to the applicant entering into this Agreement;

NOW THEREFORE in consideration of the issuance of the Permit by the City authorizing the Permit Holder to conduct Business on a Highway area belonging to the City, the Permit Holder agrees as follows:

In this Agreement, "Licence Area" means the area of City Sidewalk used by the Permit Holder for a Sidewalk Sales or Seating Area and terms with initial capitals not defined in this Agreement shall be interpreted in accordance with the City of Penticton Traffic Bylaw No. 94-39.

23. The City grants to the Permit Holder a licence to occupy the Licence Area for the purpose only of operating a Sidewalk Sales or Seating Area, and only in accordance with the terms of this Agreement.
24. The right to occupy shall be for the calendar year ____ and, unless terminated pursuant to this Agreement, may thereafter be renewed annually for a subsequent calendar year, upon payment of the annual fees set out in section 10B of the City of Penticton Traffic Bylaw No. 94-39.
25. The Permit Holder shall display the Permit in the Business premises in relation to which it was issued, in such manner as to be clearly visible to members of the public.
26. The Permit Holder shall use the Licence Area only in accordance with the terms of the Permit and any applicable City bylaws, and the Permit Holder shall permit the Manager of Regulatory Services to enter the Licence Area and the Business premises to which it is appurtenant at any time, for the purpose of monitoring compliance with this Agreement and the Permit.
27. The right to use the Licence Area granted by the Permit and this Agreement is subject at all times to the right of the City and any public utility, and the employees and contractors of either of them, to enter the Licence Area without notice or reimbursement to the Permit Holder, for the purpose of installation, maintenance and repair of pavement, curb and gutter, Sidewalk, pipes, cables, conduits, wires, poles or any other service or installation permitted in a Highway.
28. The Permit Holder shall maintain the Licence Area and the adjacent pavement, Sidewalk and Boulevard in a clean and sanitary condition free from grease, papers, rubbish and debris, to the satisfaction of the Manager of Regulatory Services.
29. The Permit Holder shall maintain the improvements authorized by the Permit to be placed in the Licence Area in good condition, keeping all displayed products and display apparatus properly aligned and properly finished.
30. The Permit Holder shall not erect any buildings or structures in the Licence Area other than those specifically authorized by the Permit.
31. The Permit Holder shall vacate the Licence Area at the end of the term of this Agreement if the Agreement is not renewed, or upon the earlier termination of this Agreement if the Permit is revoked, by removing all fixtures, chattels and objects of the Permit Holder and making good any damage to the Sidewalk caused by the installation or removal of fixtures.

32. The Permit Holder shall remove all fixtures, chattels and objects of the Permit Holder from the Licence Area when required to do so by a police officer, municipal bylaw enforcement officer, the Public Works Manager or the Manager of Regulatory Services so as to temporarily restore the use of the Licence Area as a Sidewalk.
33. The Permit Holder acknowledges that upon its failure to comply with section 9 or 10, the City may remove all fixtures, chattels and objects of the Permit Holder from the Licence Area and repair any damage at the Permit Holder's expense, and agrees to pay the City's costs of removal and, if necessary, storage of such materials and repair of damage, promptly on receipt of the City's account in that regard.
34. The Permit Holder further acknowledges that any fixtures, objects or chattels removed and stored by the City and not claimed within sixty days of removal shall become the property of the City, and may be sold and the proceeds retained by the City.
35. The Permit Holder acknowledges and agrees that the licence granted by this Agreement does not permit the use of the Licence Area in any manner that would have the effect of blocking or impairing the entrance to any premises adjacent to the Licence Area.
36. The City shall not be liable directly or indirectly, for any personal injuries that may be suffered or sustained by any Person who may be in the Licence Area or for any loss or damage or injury to property belonging to the Permit Holder or any other Person and located in the Licence Area, unless such injury, loss or damage is due to the City's negligence or default, or negligence or default of those for whom the City is in law responsible.
37. The Permit Holder shall at all times indemnify and save harmless the City and its officials, officers, employees, servants and agents from all cost, losses, damages, compensation and expenses, including actual legal fees, of any nature whatsoever suffered or incurred by the City and caused or sustained by the Permit Holder's occupation or possession of the Licence Area, and from all claims, demands, suits and judgments against the City or its officials, officers, employees, servants and agents on account of or in respect of the Licence Area or the occupation or possession of the Licence Area by the Permit Holder, its servants, agents, contractors, or invitees.
38. The Permit Holder shall at its own expense provide and maintain comprehensive general liability insurance in the minimum amount of \$2,000,000.00 per occurrence against bodily injury and property damage, naming the City and its officials, officers, employees, servants and agents as additional insured's, and shall provide a certificate evidencing the insurance at the time of executing this

Agreement and thereafter as required by the City. Such insurance shall contain provisions for cross-liability and severability of interest, and shall be endorsed to provide that the policy will not be changed in any way or cancelled until thirty days after written notice of such change or cancellation shall have been given to the City.

39. The Permit Holder shall not assign the right to use the Licence Area to any other person without the express written consent of the City, and any such assignment shall be in writing. In the event that the Permit Holder transfers its interest in the Business premises abutting or adjacent to the Licence Area, the Permit Holder shall obtain the consent of the City to the assignment of the licence granted by this Agreement.
40. This Agreement does not exempt the Permit Holder from any obligations created by any bylaws of the City affecting the use of the Licence Area of the business premises to which the Licence Area is appurtenant, including without limitation any business bylaw, business licence bylaw, building bylaw, or sign bylaw.
41. If the Permit Holder shall be in default in performing its obligations under the Permit or this Agreement, the City may give written notice to the Permit Holder of such default giving the Permit Holder seven days to remedy such default, or such shorter time as the Manager of Regulatory Services may deem appropriate in circumstances constituting a hazard to the public, failing which the City may, by further written notice to the Permit Holder, immediately revoke the Permit and terminate the licence granted by this Agreement.
42. Any notice to the Permit Holder contemplated by this Agreement may be given to the Permit Holder at the address of the business premises to which the Licence Area is appurtenant.
43. This Agreement shall enure to the benefit of and be binding upon the parties hereto and their respective heirs, executors, administrators, successors and permitted assigns, as the case may be.

IN WITNESS WHEREOF the parties hereto have hereunto executed this agreement as of the date and year first above written.

(Name of Permit Holder)

THE CORPORATION OF
THE CITY OF PENTICTON

By its authorized signatory(ies):

Name:

Manager of Regulatory Services

Name:

SCHEDULE - N

SIDEWALK SALES AREA SPECIFICATIONS

1. The applicant for a Sidewalk Sales Area must submit a written description of the merchandise which is proposed to be displayed in the Sidewalk Sales Area.
2. The use of the Sidewalk as a Sidewalk Sales Area shall be limited to the placement of display apparatus upon which products are displayed or alternatively products may be placed directly upon the sidewalk surface or a combination thereof.
3. A Sidewalk Sales Area and any display apparatus shall not occupy more than 1.07 meters (42 inches) of Sidewalk width or leave less than 1.5 meters (5-feet) of clear, unobstructed Sidewalk for pedestrian use. The clear Sidewalk space shall be measured from the Sidewalk Sales Area display to the curb edge of the Sidewalk or to any other obstruction such as trees, benches or planter or to any other permanent or temporary obstruction.
4. The maximum height of a Sidewalk Sales Area including display apparatus and products must not be greater than 1.8 meters (6-feet), measured from the surface of the Sidewalk.
5. Where products are displayed either directly upon the surface of the Sidewalk or using display apparatus such that the display is at a level lower than 1.07 meters (42 inches) above the Sidewalk surface, a visual barrier must be provided around the Sidewalks Sales Area and must be of a color and design such that it can be easily identified by pedestrians.
6. Any display apparatus must be in good repair and free from any defects that may be hazardous to pedestrians.
7. Products being displayed in a Sidewalk Sales Area must be of an arrangement such that they do not pose a hazard to pedestrians.
8. The use of chairs for vending staff is not restricted provided the chair(s) are confined within the limitations of the Sidewalk Sales Area.
9. The use of umbrellas to protect the Sidewalk Sales Area is not restricted provided the umbrella(s) are located within the limitations of the Sidewalk Sales

Area and the umbrella(s) must be secured and there must be a clear height under the umbrella(s) of not less than 2.1 meters (7-feet).

10. A Sidewalk Sales Area shall not block or restrict the normal access to the doorway(s) of the Business or accesses to neighboring properties.
11. A Sidewalk Sales Area is permitted to operate on any and all days within the term of the Sidewalk Sales Area Permit except on days or times where a City sanctioned event or other City permit restricts the use of the public Sidewalk and or Roadway directly adjacent to the Sidewalk Sales Area. Such City sanctioned events shall include, but not be limited to, parades, festivals, sporting or cultural events, memorial services, road closures or maintenance or repairs works.
12. A Sidewalk Sales Area is not permitted to operate in conjunction with any other Sidewalk use.
13. All products, display apparatus, chairs and umbrellas must be removed from the Sidewalk during times when the Business holding the Sidewalk Sales Area Permit is not open to the public and all display apparatus, chairs and umbrellas must be removed from the Sidewalk when they are not being used to display products.
14. Signage is not permitted in the Sidewalk Sales Area.
15. The Sidewalk Sales Area Permit Holder shall not erect on the Sidewalk any buildings or structures other than display apparatus such as tables or racks.
16. A Sidewalk Sales Area shall not extend onto the Sidewalk in front of adjacent Business unless a written agreement between Businesses is provided to the City and each of the Businesses has a Sidewalk Sales Area Permit.
17. The Sidewalk Sales Area Permit Holder shall be responsible for ensuring that the Sidewalk adjacent to the Business is kept in a clean state.

SIDEWALK SEATING AREA SPECIFICATIONS

1. The applicant for a Sidewalk Seating Area must drawing showing the location of the table and chairs to be displayed in the Sidewalk Seating Area.
2. The use of the Sidewalk as a Sidewalk Seating Area shall be limited to the placement of two (2) tables and eight (8) chairs.
3. A Sidewalk Seating Area shall not occupy more than 1.07 meters (42 inches) of Sidewalk width or leave less than 1.5 meters (5-feet) of clear, unobstructed

Sidewalk for pedestrian use. The clear Sidewalk space shall be measured from the Sidewalk Seating Area display to the curb edge of the Sidewalk or to any other obstruction such as trees, benches or planter or to any other permanent or temporary obstruction.

4. Any tables and chairs must be in good repair and free from any defects that may be hazardous to users or pedestrians.
5. The use of umbrellas to protect the Sidewalk Sales Area is not restricted provided the umbrella(s) are located within the limitations of the Sidewalk Sales Area and the umbrella(s) must be secured and there must be a clear height under the umbrella(s) of not less than 2.1 meters (7-feet).
6. A Sidewalk Sales Area shall not block or restrict the normal access to the doorway(s) of the Business or accesses to neighboring properties.
7. A Sidewalk Seating Area is permitted to operate on any and all days within the term of the Sidewalk Sales or Seating Area Permit except on days or times where a City sanctioned event or other City permit restricts the use of the public Sidewalk and or Roadway directly adjacent to the Sidewalk Sales or Seating Area. Such City sanctioned events shall include, but not be limited to, parades, festivals, sporting or cultural events, memorial services, road closures or maintenance or repairs works.
8. A Sidewalk Seating Area is not permitted to operate in conjunction with any other Sidewalk use.
9. All tables and chairs must be removed from the Sidewalk during times when the Business holding the Sidewalk Sales or Seating Area Permit is not open to the public.
10. Signage is not permitted in the Sidewalk Seating Area.
11. The Sidewalk Sales or Seating Area Permit Holder shall not erect on the Sidewalk any buildings or structures other than tables or chairs.
12. A Sidewalk Sales Area shall not extend onto the Sidewalk in front of adjacent Business unless a written agreement between Businesses is provided to the City and each of the Businesses has a Sidewalk Sales or Seating Area Permit.
13. The Sidewalk Sales or Seating Area Permit Holder shall be responsible for ensuring that the Sidewalk adjacent to the Business is kept in a clean state.

SCHEDULE "O" - PARKING STALL RENTAL LICENCE

DEPARTMENTAL CONTACT: City Clerk Department 171 Main Street Penticton, B.C. V2A 5A9 (250) 490-2400	PARKING LOT: <input type="checkbox"/> Braeburn Lot, 223 Robinson Street <input type="checkbox"/> Gala Lot, 355, Ellis Street <input type="checkbox"/> McIntosh Lot, 421 Ellis Street <input type="checkbox"/> Spartan Lot, 503 Ellis Street	PARKING STALL NUMBER: (insert assigned parking stall number) (the licence is valid for the parking stall number as indicated above, only)								
1	2 (the licence is valid for the parking lot as indicated above, only)	3								
THIS LICENCE IS AUTHORIZED BY: The Corporation of the City of Penticton (the "City")	VEHICLE INFORMATION: MAKE OF VEHICLE: _____ MODEL OF VEHICLE: _____	EFFECTIVE DATE OF THIS LICENCE: _____, _____, _____ YEAR MONTH DAY								
4	5	6								
LICENSEE'S LEGAL NAME: _____ (please print)	NOTICE ADDRESS: (if required the City will notify the licensee at this address) _____ _____ _____ LICENSEES PHONE NUMBER: (if required the City will notify the licensee at this phone number) (____) _____ - _____									
7	8									
THE LICENSEE IS HEREBY AUTHORIZED TO: Park their private vehicle in a designated stall assigned by the City (the "Stall"). The City reserves the right to assign a parking stall in a different location of the parking area if necessary, from time to time.										
9	FEES: Payment terms: <table style="margin-left: 40px; border: none;"> <tr> <td style="text-align: center;">Monthly</td> <td style="text-align: center;">Semi-annually</td> </tr> <tr> <td style="text-align: center;"><input type="checkbox"/></td> <td style="text-align: center;"><input type="checkbox"/></td> </tr> <tr> <td style="text-align: center;">Quarterly</td> <td style="text-align: center;">Annually</td> </tr> <tr> <td style="text-align: center;"><input type="checkbox"/></td> <td style="text-align: center;"><input type="checkbox"/></td> </tr> </table>		Monthly	Semi-annually	<input type="checkbox"/>	<input type="checkbox"/>	Quarterly	Annually	<input type="checkbox"/>	<input type="checkbox"/>
Monthly	Semi-annually									
<input type="checkbox"/>	<input type="checkbox"/>									
Quarterly	Annually									
<input type="checkbox"/>	<input type="checkbox"/>									
10	THIS LICENCE EXPIRES ON: _____, _____, _____ YEAR MONTH DAY 11									
CONDITIONS ADDITIONAL TO THOSE ON REVERSE OF THIS DOCUMENT										
YES (see page 2) (attach additional page if required) <input type="checkbox"/>										
TERMS AND CONDITIONS ON REVERSE SIDE ARE PART OF THIS LICENCE										
THE PARTIES HAVE SIGNED THE LICENCE AS OF THE DATE: _____, _____, _____ _____ YEAR MONTH DAY Signature of the Licensee _____ Signed for the City of Penticton _____ Title:										

TERMS AND CONDITIONS

1. **In this Licence:**
"Manager of Regulatory Services" means the person holding the position or acting in the capacity of the Manager of Regulatory Services for the time being, or such person as is designated by the City to administer this Licence on behalf of the City.
2. **Form**
This document and any attachments mentioned as forming part of this Licence constitute the entire Licence between both parties when duly executed by both parties. No variation thereof shall be effective without the written consent of both parties. No local, general or trade customs shall be deemed to vary the terms and conditions thereof.
3. **Payment of Fees**
The Licensee shall pay all fees herein reserved at the time and in the manner in this Licence as set forth, without any abatement or deduction whatever.
4. **Fees review**
The City reserves the right to modify the fees herein reserved, provided written notice of each modification is given to the Licensee.
5. **Assignment**
The Licensee shall not assign or transfer this Licence in whole or in part without the prior consent of the City.
6. **Compliance with Regulations and Directives**
The Licensee shall in all respects abide and comply with all applicable lawful rules, regulations, and bylaws of the Federal, Provincial or Municipal governments or any other governing body whatsoever. The Licensee shall abide by and comply with all directives issued from time to time by the City concerning the use of the Stall. All vehicles in violation of the aforesaid may be towed and the owner responsible for the costs of impounding and towing.
7. **Access**
The officers, servants and agents of the City shall, at all times and for all purposes, have full and free access to the Stall.
8. **Risks**
All property of the Licensee, at any time brought to the Stall shall be entirely at the risk of the Licensee, with the exception only of any such loss, damage or injury caused by the negligence of any officer, servant or agent of the City while acting within the scope of his or her duties or employment.
9. **Indemnification**
The Licensee shall at all times indemnify and save harmless the City, its elected officials and employees and be responsible for all claims and demands, loss, costs, damages, actions, suits or other proceeding by whomsoever made, brought or prosecuted, based upon or attributable to this Licence or any actions taken or things done by the Licensee, unless such damage or injury is due to the negligence of any officer, servant or agent of the City while acting within the scope of his or her duties or employment.
10. **Damage**
Any damage or injury which may, during the existence of this Licence be occasioned to the Stall or any part thereof, or works connected therewith, by the Licensee or the activities of the Licensee shall, immediately upon notice thereof from the City given either verbally or in writing, be repaired, rebuilt, replaced and restored by the Licensee to the entire satisfaction of the City, or the City may, at its option, repair such damage or injury, in which case the Licensee shall upon demand forthwith repay and reimburse the City for all costs and expenses connected therewith or incidental thereto.
12. **Insurance**
The Licensee shall maintain at all times during the currency of the Licence general liability insurance, for an amount of coverage and in a form acceptable to the City. The Licensee shall provide the City with written proof that he or she maintains such insurance coverage, if and when requested. The Licensee's vehicle parked in the Stall shall at all times be licensed and insured to operate on a public road.
13. **Default or Breach**
Upon default or breach in respect of any provision or condition herein, the City may, with or without notice, retake possession of the Stall and thereupon, the Licensee shall forthwith remove his or her property from the Stall and upon his or her failure to do so, the said property shall become the property of and shall vest in the City, without any right of compensation on the part of the Licensee therefore.
compensation on the part of the Licensee therefore.
14. **Cancellation**
This Licence may be cancelled with or without cause forthwith at any time by either party by notice in writing delivered to

the other party or mailed to his or her last known address.

15. Licence Restriction

This Licence is only for the assigned Stall and may not be used for parking in other City parking stalls or lots.

16. Type of Vehicles

Only one passenger vehicle or motorcycle is permitted in the Stall at any time. Recreation vehicles, travel trailers or commercial vehicles, having a GVW of over 5,600 kgs., industrial vehicles or equipment are not permitted.

17. Display

The Licensee vehicle shall at all times properly display this licence (placard), which must be hung from the rear view mirror of the vehicle, be placed face up and fully visible on the dashboard or hung from the handle bars of a motorbike.

18. Snow and Ice

The Licensee shall clear all snow and ice accumulations from the Stall. The City shall not be responsible for loss or injury due to ice and snow accumulations on or around the Stall. The City will clear ice and snow from the parking lot in which the Stall is situate as per current City policy but cannot ensure that ice and snow are removed from the Stall.

SCHEDULE “P”

Description of Infraction	Code	Section
OVERTIME PARKING		
• Meter Expired	94-39A 01-01	3.2(B)5
• Voucher Expired	94-39A 01-02	3.2(A)28
• Over 1 Hour	94-39A 01-03	3.2(A)27(a)
• Over 2 Hours	94-39A 01-04	3.2(A)27(a)
• Over 15 Minutes	94-39A 01-05	3.2(A)27(a)
NO PARKING VOUCHER		
• Voucher not Visible	94-39A 02-01	3.2(A)28
• Voucher not clearly Displayed	94-39A 02-02	3.2(A)28
• Voucher upside down	94-39A 02-03	3.2(A)28
• Voucher from Wrong Lot	94-39A 02-04	3.2(A)28
PARKING OR OVERPARKING IN LANE		
• Over 15 Minutes	94-39B 01-01	3.2(A)3
• Obstructing Traffic Flow	94-39B 01-02	3.2(A)3
• Contrary to Signage	94-39B 01-03	3.2(A)14
THEATRE OR HOTEL ZONE		
	94-39B 02-01	3.2(A)8
NO STOPPING ZONE		
• Contrary to Signage	94-39B 03-01	3.2(A)14
• Within a Bus Stop	94-39B 03-02	3.2(A)14
• Within a School Zone	94-39B 03-03	3.2(A)14
• In Designated Bike Lane	94-39B 03-04	3.2(A)26
• On a Crosswalk	94-39B 03-05	3.2(A)6
PARKING MORE THAN 24 HOURS		
	94-39B 04-01	3.2(A)20
COMMERCIAL VEHICLE OVER 5600 KG. GVW ON HIGHWAY IN RESIDENTIAL DISTRICT		
	94-39B 05-01	3.2(A)21
HANDICAP ZONE		
• Permit not Displayed	94-39B 06-01	3.2(A)32
• Permit Expired	94-39B 06-02	3.2(A)32
VEHICLE OVER 6 M. IN LENGTH		
	94-39B 07-01	3.2(A)18
NO PARKING ZONE		
• Contrary to Signage	94-39B 08-01	3.2(A)14
• On a sidewalk or Boulevard	94-39B 08-02	3.2(A)1
• In front of a Public or Private Driveway	94-39B 08-03	3.2(A)2
• Within an Intersection	94-39B 08-04	3.2(A)4
• Upon a Bridge	94-39B 08-05	3.2(A)13
• Within 5 m. of a Fire Hydrant	94-39B 08-06	3.2(A)5
• On a Crosswalk or within 6 m. of the Approach Side	94-39B 08-07	3.2(A)6
• Within 6 m. upon the Approach of a Stop	94-39B 08-08	3.2(A)7

Sign or Traffic Control Signal		
• Within 6 m. either side of Entrance or Exit from any Hotel, Theatre, Public Meeting Place, Fire Hall or Playground	94-39B 08-09	3.2(A)8
• Within 3 m. of the Entrance or Exit of a Lane	94-39B 08-10	3.2(A)22
• Within a Designated Public or Private Emergency Vehicle area	94-39B 08-11	3.2(A)33
• In a Resident Parking Only Area without Valid Permit Displayed	94-39B 08-12	3.2(A)34
• In a Loading Zone unless Actively Loading or Unloading	94-39B 08-13	3.2(A)14
• In a Space Reserved for use of Federal or Municipal Officials	94-39B 08-14	3.2(A)19
• For Purpose of Vehicle Sale	94-39B 08-15	3.2(A)10(a)
• For Purpose of Advertising or Displaying Signs	94-39B 08-16	3.2(A)10(b)or(c)
• For Purpose of Selling Commodities or Articles	94-39B 08-17	3.2(A)10(d)
• For Purpose of Vehicle Storage	94-39B 08-18	3.2(A)10(b)
• For Purpose of Vehicle repairs	94-39B 08-19	3.2(A)10(b)
IMPROPERLY PARKED		
• Obstructing Traffic Flow	94-39B 09-01	3.2(A)23
• Obstructing Visibility of a Traffic Control Device	94-39B 09-02	3.2(A)15
• Double Parked	94-39B 09-03	3.2(A)12
• Over 30 cm. from the Curb	94-39B 09-04	3.2(A)17
• Outside Designated Lines	94-39B 09-05	3.2(A)24
• Detached Trailer	94-39B 09-06	3.2(A)31(a)
• Vehicle without Boat Trailer Attached	94-39B 09-07	3.2(A)14
OTHER		
• Re-park within One Hour	94-39B 10-01	3.2(A)27(b)



SCHEDULE "Q"

(Front Display of Card)

SPECIAL EVENT PARKING ONLY PLACARD

This Placard is issued subject to
"CITY OF PENTICTON TRAFFIC BYLAW NO. 94-39"

This Special Event Parking Only Placard is
only valid on signed streets for the period:

(time period)

(Back of Card)

To be valid this Placard must adhere to the top drivers side
of the front windshield or placed face up on the front
dash board of the vehicle.

Where this Placard is not displayed as described
above or is not fully visible from the exterior
of the vehicle, the Placard is not valid and the vehicle
is therefore in violation of the "SPECIAL EVENT
PARKING ONLY" parking restrictions and may be
ticketed and/or towed.